



Order no.	Item no.	#	Part of the approval according to order no. 20011111
20011111	21556	1	Drive-over superstructure 2.35 Pv 170-240
	14129	1	Lifting unit ML 2.35 NxT TR KA 1550, 2000mm stroke with cardan shaft
	11063	1	Set of cables 10m (Std. EL, ML, PL, BL)
	12033	1	Ecological hydraulic fluid 10 ltr.

The Masterlift 2.35 NxT TR Pv repair platform is optimally suited for **quick and easy vehicle lifting**. The premium version is constructed of very strong and rigid **solid steel** that offers a **high degree of stability**. They are zink coated and painted. Looks great and works great!

Our premium repair platforms make the Masterlift 2.35 NxT the perfect helper in your workshop. The handy, **non-slip and form-fitting rubber pads** ensure that the vehicle is lifted with pinpoint accuracy. The **strong 140 mm diameter cylinders** are also designed for long-lasting functionality and further round off the high-quality level, which ensures **low maintenance requirements**.

Even in the event of a power blackout, the lift can still be lowered without any problems thanks to the pneumatic emergency lowering system.

The Masterlift 2.35 NxT TR Saa is perfectly completed by a **control system that is both visually and technically convincing**.

**Standard colour:**

Pv Premium: zink coated and painted – RAL 7016

**Options:**

Rubber blocks in different heights

**Frame:**

Standard: completely hot-dip galvanized  
Incl. tube connection frame

**Installation variants:**

On-floor installation  
Recessed installation  
Ceiling installation

**Standard:**

Basically self-supporting design

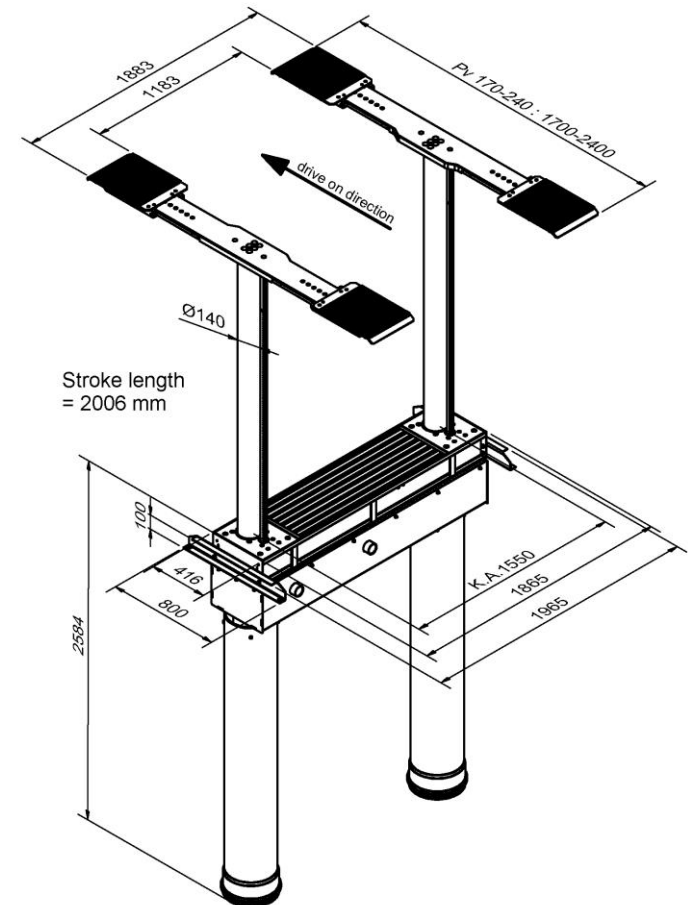

Masterlift 2.35 NxT Pv - BMW 08 502672