

Masterlift 2.35 NxT Pv BMW

Electro-hydraulic twin-ram lift, 3.5 t with repair platforms

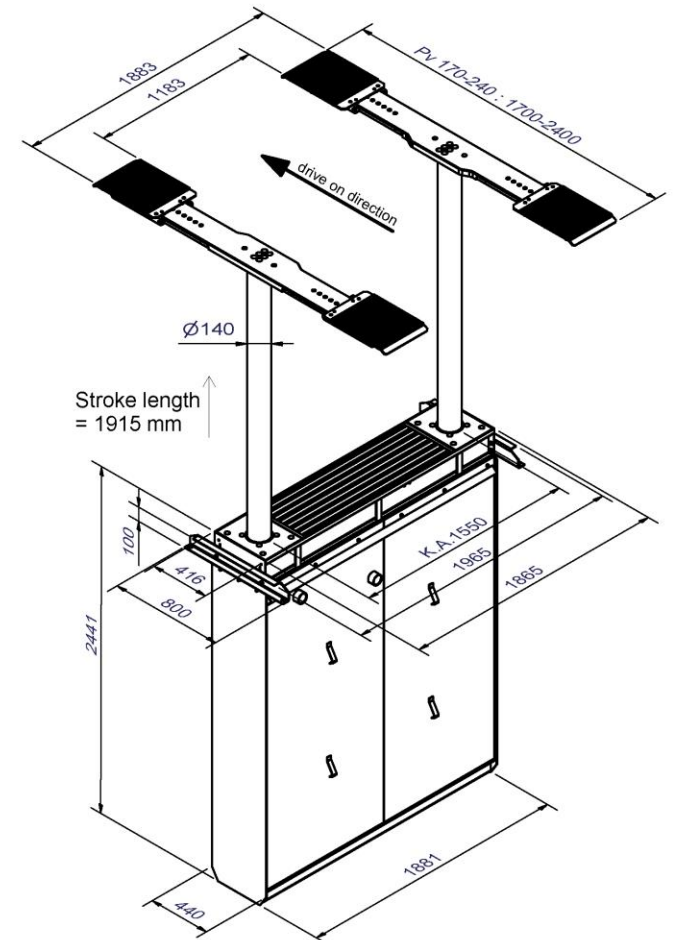

Order no.	Item no.	#	Part of the approval according to order no. 20011110
20011110	21556	1	Drive-over superstructure 2.35 Pv 170-240
	14050	1	Hydraulic unit ML 2.35 NxT, Ø 140mm, PD 1550, stroke 1915mm
	11063	1	Set of cables 10m (Std. EL, ML, PL, BL)
	12033	1	Ecological hydraulic fluid 10 ltr.



The Masterlift 2.35 NxT Pv repair platform is optimally suited for **quick and easy vehicle lifting**. The premium version is constructed of very strong and rigid **solid steel** that offers a **high degree of stability**. They are zinc coated and painted. Looks great and works great!

Our premium repair platforms make the Masterlift 2.35 NxT the perfect helper in your workshop. The handy, **non-slip and form-fitting rubber pads** ensure that the vehicle is lifted with pinpoint accuracy. The **strong 140 mm diameter cylinders** are also designed for long-lasting functionality and further round off the high-quality level, which ensures **low maintenance requirements**.

Even in the event of a power blackout, the lift can still be lowered without any problems thanks to the pneumatic emergency lowering system.

The Masterlift 2.35 NxT Saa is perfectly completed by a **control system that is both visually and technically convincing**.

Standard colour:

Pv Premium: zinc coated and painted – RAL 7016

Options:

- Rubber blocks in different heights
- Active cassette ventilation
- Moisture monitoring in the steel cassette

Versions:

- Self-supporting design without load on the bottom of the cassette
- Floor-standing design

Installation variants:

- On-floor installation
- Recessed installation
- Ceiling installation

Frame:

Standard: completely hot-dip galvanized

Sub-casing:

- Standard: painted
- Optional: hot-dip galvanized or plastic-coated

Masterlift 2.35 NxT Pv - BMW 08 502671