

Maestro 32 F BMW

Electro-mechanical 2-post lift, 3.2 t capacity



BMW 08 500934
Bestell-Nr. 20011118

| Order no. | Item no. | # | Part of the approval according to order no. 20011118: |
|-----------|----------|---|--|
| 20011118 | 089185 | 1 | Maestro 32 F - DT/DT, 400/3/50 - 4050/4350mm - Ø40 - RAL 9010/7016 |
| | 777473 | 1 | Set of 14 expansion anchor bolts - HST3 M12x115 40/20 |
| | 776477 | 1 | Portal set for Maestro 2.30/2.32/30/32, 4050mm |

The 2-post lifts of the Maestro 32/35 series impress with their premium construction.

They come with **stable bent columns**.

Smooth running is ensured by the **sliding bearing carriage**.

The **cold-rolled spindle** guarantees a **particularly long service life**.

The columns are asymmetrically positioned, i.e. vehicles can be positioned far to the rear, which ensures an **optimal door opening angle**.

Of course, the Maestro 32 also has door stop protection to prevent damage when entry and exit.

The **swivel arms are extremely flat** and thus ensure a **low minimum height**. The **internal arm locking system** with strong 360° interlocking protects against moisture and dirt.

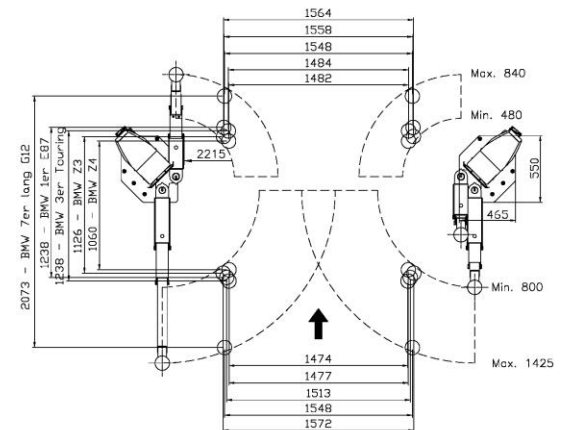
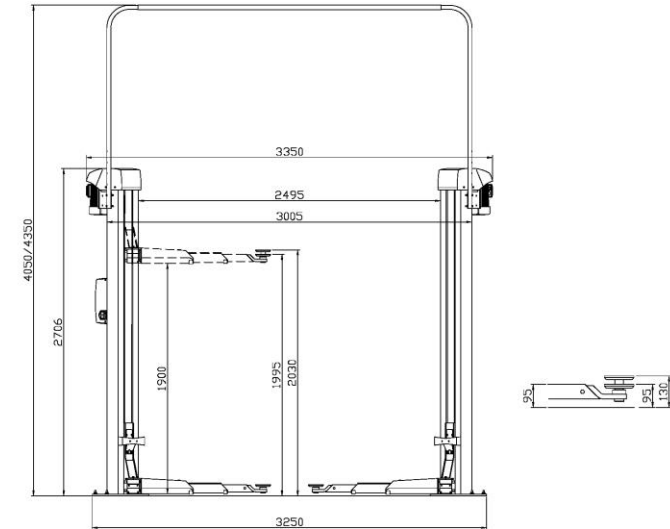

Standard colour:

Arms: RAL 3020

Posts: RAL 7016

Versions:

Available for different voltages

F = flex pad

Options:

Available with different portal heights

LED lighting set

Energy set with compressed air and socket-outlet

Extra control unit for second column

Large program of extra pads, depending on type of vehicle