



Biglift 4.55 Combi MB

Electro-hydraulic 4-ram lift, 5.5 t with platforms and free-wheel lift with arms



MB H22 13 10 7A
Order no.
20010105-1 | 20010105-2

Bestell-Nr.	Art.-Nr.	#	Part of the approval according to order no. 20010105-1/-2:
20010105-1	21509	1	Superstructure BL 4.55 Fn 550 Combi, on floor
	21205	1	Superstructure BL 4.55 Saav 155 Combi incl. lifting pads
	21100	1	Drive-on ramp, on floor, 1100 mm, 10°, 1 set = 2 pcs.
	21084	1	Roll-off safety device, h = 100 mm, 1 set = 2 pcs.
	12465	1	M, Mercedes-approval and painting - F - grey RAL 7015
	12172	1	M, Mercedes-approval and painting - S - grey RAL 7015
	12407	1	Extra charge zinc coated and painted platforms ML, PL, BL
	21080	1	Power distribution for one platform
	21096	1	Pneumatic installation for 1 side of the platform
	11103	1	Document holder AUTOPSTENHOJ
20010105-2	11104	1	Magnetic tool tray set, 1 set = 2 pcs.
	10295	1	Hydraulic unit BL 4.55 Combi, PD 1240, stroke 1850 mm
	12038	1	Ecological hydraulic fluid 20 ltr.
	11109	1	16A circuit breaker in the control box
			Not part of the approval (options)
	11071	1	Set of cables 10 m
	12245	1	Cassette BL Combi, 5,5 t

Die Biglift 4.55 Combi repair platform is optimally suited for **quick and easy vehicle lifting**.

The premium version is constructed of very strong and rigid **solid steel** that offers a **high degree of stability**.

They are zinc coated and painted. Looks great and works great!

The additional swivel arm superstructures, **as standard equipped with double telescopic and transversely moveable swivel arms**, make the Biglift 4.55 Combi the perfect helper in your workshop.

Four strong 2x123 mm diameter double cylinders are also designed for long-lasting functionality and further round off the high-quality level, which ensures **low maintenance requirements**.

Even in the event of a power blackout, the lift can still be lowered without any problems thanks to the pneumatic emergency lowering system.

The Biglift 4.55 Combi is perfectly completed by a **control system that is both visually and technically convincing**.

Standard color:

RAL 7015 grey

Installation:

Superstructure on floor

Superstructure recessed, with or without flush floor device

Steel cassette:

Standard: Primed

Optional: Hot-dip galvanised or plastic-coated

Options:

Large program of extra pads depending on type of vehicle

LED lighting set

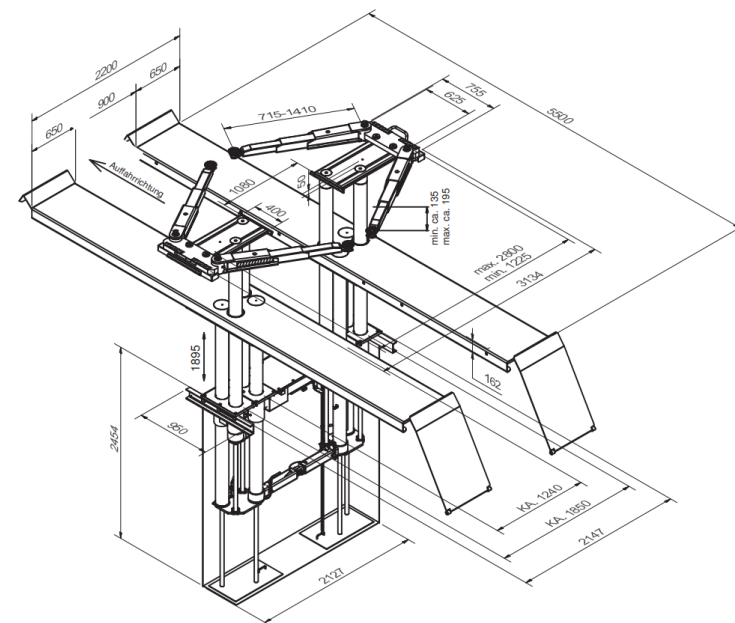

The product meets the requirements for workshop equipment for MB service workshops and is recommended by Mercedes Benz with approval no. H22 13 10 7A

Biglift 4.55 Combi – H22 13 10 7A