



Biglift 2.55 Saa 265 MB

Electro-hydraulic twin-ram lift, 5.5 t with superstructure with arms



MB H21 01 04 1B
Order no.
20010104-1 | 20010104-2

Order no.	Item no.	#	Part of the approval according to order no. 20010104-1/-2:
20010104-1	21203	1	Superstructure BL 2.55 Saa 265 incl. lifting pad
	12172	1	M, mercedes approval and paint type: "S", RAL 7015 grey
	11103	1	Document holder AUTOPSTENHOJ
	11104	1	Magnetic tool tray set, 1 set = 2 pcs.
20010104-2	10309	1	Hydraulic unit BL 2.55, Ø213, PD 2650, stroke 1860 mm
	12036	1	Ecological hydraulic fluid 17 ltr.
			Not part of the approval (options)
	11063	1	Set of cables 10 m
	12106	1	Cassette PD 2650 BL

The double telescopic swivel arms convince with a **non-standard lifting area**, which even makes it possible to lift commercial vehicles and large cars without any problems.

The **internal arm locking system** installed as standard reliably protects against external influences. An integrated mechanical safety ratchet provides additional safety for all work processes.

The **strong 213 mm diameter cylinders** are also designed for long-lasting functionality and further round off the high-quality level, which ensures **low maintenance requirements**.

Even in the event of a power blackout, the lift can still be lowered without any problems thanks to the pneumatic emergency lowering system.

The Biglift 2.55 Saa 265 is perfectly completed by a **control system that is both visually and technically convincing**.

Standard color:

RAL 7015

Option:

Large program of extra pads, depending on type of vehicle

Installation:

Superstructure on floor
Superstructure recessed with covers
Ceiling installation

Steel cassette:

Standard: Primed
Optional: Hot-dip galvanised or plastic-coated

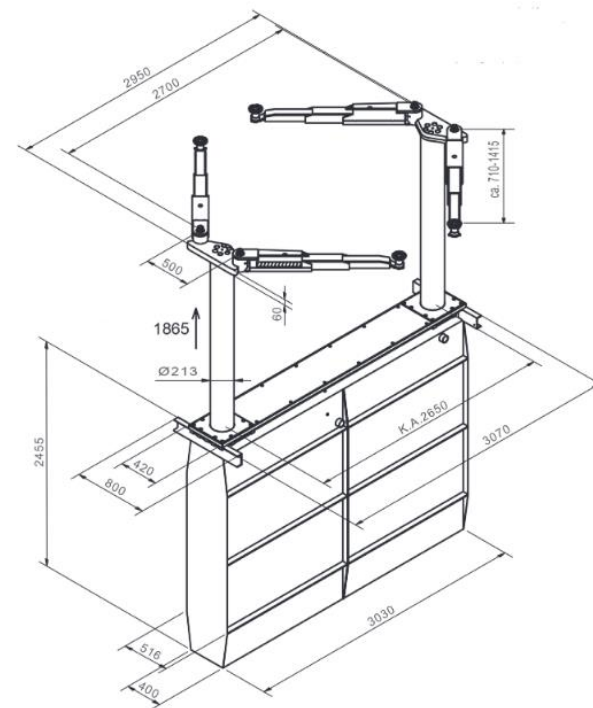

The product meets the requirements for workshop equipment for MB service workshops and is recommended by Mercedes Benz with approval no. H21 01 04 1B.

Biglift 2.55 Saa 265 – H21 01 04 1B