



# Product catalogue

Mercedes-Benz approved products



Inground lifts | Surface mounted lifts



# Masterlift 2.35 NxT Pv 160-220 xy MB

Electro-hydraulic twin-ram lift, 3.5 t with repair platforms

The product meets the requirements for workshop equipment for MB service workshops and is recommended by Mercedes Benz with approval no. H13 01 01 1A.

Masterlift 2.35 NxT Pv – H13 01 01 1A



Order no.	Item no.	#	Part of the approval according to order no. 20010100:
20010100	14107	1	Superstructure ML 2.35 Pv 160-220 xy
	16070	1	Hydraulic unit ML 2.35 NxT, Ø140, PD 1350, stroke 1915mm incl. Side covers for cassette PD 1550
	12033	1	Ecological hydraulic fluid 10 ltr.
	12462	1	Mercedes approval and painting type: "Pv", RAL 7015 grey
	11102	1	Rubber blocks 40mm, 1 set = 4 pcs.
	11103	1	Document holder "AUTOPSTENHOJ"
	11104	1	Magnetic tool tray set, 1 set = 2 pcs.
	11063	1	Set of cables 10 m
	14096	1	Cassette ML PD 1550

The Masterlift 2.35 NxT Pv repair platform is optimally suited for **quick and easy vehicle lifting**.

The premium version is constructed of very strong and rigid **solid steel** that offers a **high degree of stability**. They are zink coated and painted. Looks great and works great! Alternatively, we also offer an economical version made from a welded profile that is hot dip galvanized.

Various lengths of repair platforms, which come with **xy-function in the premium version as standard**, make the Masterlift 2.35 NxT the perfect helper in your workshop. Optionally, longitudinally adjustable supports can be supplied instead of the xy function.

The handy, **non-slip and form-fitting rubber pads** ensure that the vehicle is lifted with pinpoint accuracy.

The **strong 140 mm diameter cylinders** are also designed for long-lasting functionality and further round off the high-quality level, which ensures **low maintenance requirements**.

Even in the event of a power blackout, the lift can still be lowered without any problems thanks to the pneumatic emergency lowering system.

The Masterlift 2.35 NxT Saa is perfectly completed by a **control system that is both visually and technically convincing**.

### Standard color:

Pv Premium: zink coated and painted - RAL 9006

Pv Standard: hot-dip galvanized, without painting

### Options:

Longitudinally adjustable supports

Rubber blocks in different heights

### Frame:

Standard: completely hot-dip galvanized

### Sub-casing:

Standard: painted

Optional: hot-dip galvanized or plastic-coated

### Installation variants:

On-floor installation

Recessed installation (only for Pv Premium)

Ceiling installation

### Versions:

Synchronisation and safety via synchronisation bar and toothed rack

Self-supporting installation, without load on the bottom of the sub-casing

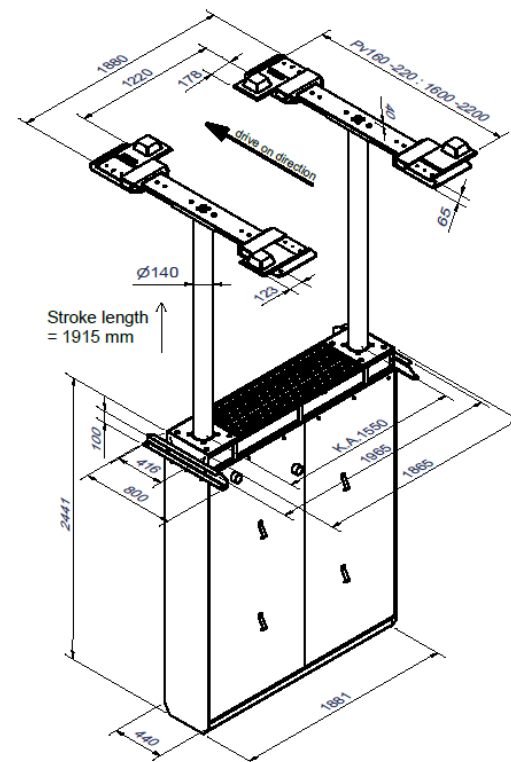



# Masterlift 2.35 NxT Saav 155 MB

Electro-hydraulic twin-ram lift, 3.5 t with adjustable swivel arms

The product meets the requirements for workshop equipment for MB service workshops and is recommended by Mercedes Benz with approval no. H11 01 01 1A.

Masterlift 2.35 NxT Saav – H11 01 01 1A



**MB H11 01 01 1A**  
Order no.  
20010101-1 | 20010101-2

Order no.	Item no.	#	Part of the approval according to order no. 20010101-1/-2:
20010101-1	21545	1	Superstructure ML 2.35 Saa 155 "VAN"- Universal incl. lifting pad
	12172	1	M, Mercedes approval and paint type: "S", RAL 7015 grey
	11103	1	Document holder AUTOPSTENHOJ
	11104	1	Magnetic tool tray set, 1 set = 2 pcs.
20010101-2	14050	1	Lifting unit ML 2.35 NxT, Ø140, PD 1550, stroke 1915 mm
	12033	1	Ecological hydraulic fluid 10 ltr.
			<b>Not part of the approval (options)</b>
	11063	1	Set of cables 10 m
	14096	1	Cassette ML PD 1550

The double telescopic swivel arms convince with an **unconventional lifting area**, especially suitable for off-road vehicles and vans.

The **internal arm locking system** installed as standard reliably protects against external influences.

The **strong 140 mm diameter cylinders** are also designed for long-lasting functionality and further round off the high-quality level, which ensures **low maintenance requirements**.

Even in the event of a power blackout, the lift can still be lowered without any problems thanks to the pneumatic emergency lowering system.

The Masterlift 2.35 NxT Saav VAN is perfectly completed by a **control system that is both visually and technically convincing**.

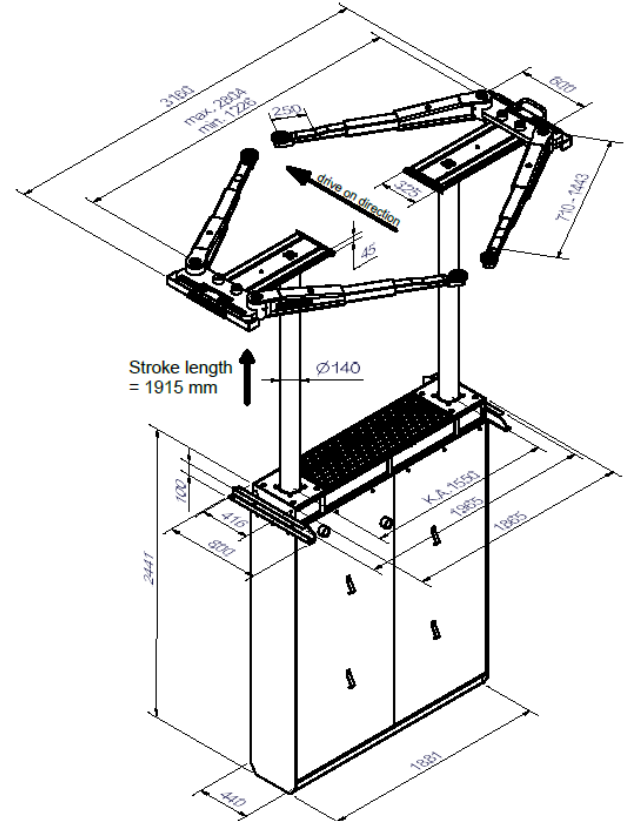

### Standard color:

Base plate: RAL 7016  
Arms: RAL 3020 - optionally with KTL coating

### Options

Wide range of extra pads, depending on vehicle type.  
Special colours on request

### Frame:

Standard: completely hot-dip galvanized

### Sub-casing:

Standard: painted  
Optional: hot-dip galvanized or plastic coated

### Installation variants:

On-floor installation  
Ceiling installation

### Versions:

Synchronisation and safety via synchronisation bar and toothed rack.  
Self-supporting installation, without load on the bottom of the sub-casing.



# Masterlift 2.35 NxT Saa 260 MB

Electro-hydraulic twin-ram lift, 3.5 t with swivel arms

The product meets the requirements for workshop equipment for MB service workshops and is recommended by Mercedes Benz with approval no. H11 01 16 1A

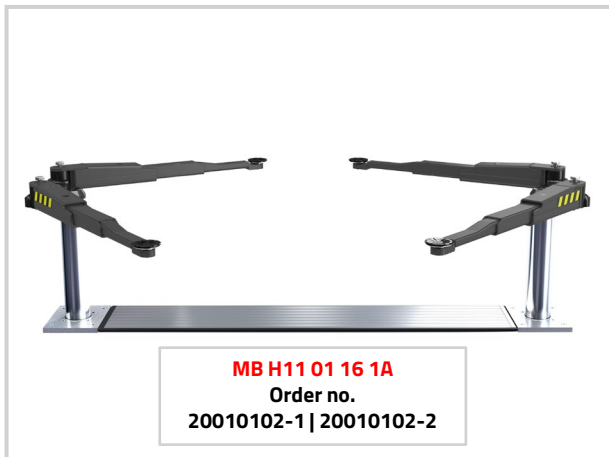

**MB H11 01 16 1A**  
Order no.  
20010102-1 | 20010102-2

Order no.	Item no.	#	Part of the approval according to order no. 20010102-1/-2:
20010102-1	21214	1	Superstructure ML 2.35 Saa 260- Universal incl. lifting pad
	12172	1	M, Mercedes approval and paint type: "S", RAL 7015 grey
	11103	1	Document holder AUTOPSTENHOJ
	11104	1	Magnetic tool tray set, 1 set = 2 pcs.
20010102-2	14051	1	Lifting unit ML 2.35 NxT, Ø140, PD 2600, stroke 1915 mm
	12033	1	Ecological hydraulic fluid 10 ltr.
			<b>Not part of the approval (options)</b>
	11063	1	Set of cables 10 m
	14097	1	Cassette ML PD 2600

The double telescopic swivel arms convince with a **very low minimum height**, which even makes it possible to lift low-profile sports cars without any problems. Tyres and rims are protected in the best possible way by the rounded design of the superstructure's chassis. The **internal arm locking system** installed as standard reliably protects against external influences.

The **strong 140 mm diameter cylinders** are also designed for long-lasting functionality and further round off the high-quality level, which ensures **low maintenance requirements**. Even in the event of a power blackout, the lift can still be lowered without any problems thanks to the pneumatic emergency lowering system. The Masterlift 2.35 NxT Saa is perfectly completed by a **control system that is both visually and technically convincing**.

### Standard color:

Base plate: RAL 7016  
Arms: RAL 3020 - optionally with KTL coating

### Options:

Wide range of extra pads, depending on vehicle type  
Special colours on request

### Frame:

Standard: completely hot-dip galvanized

### Sub-casing:

Standard: painted  
Optional: hot-dip galvanized or plastic-coated

### Installation variants:

On-floor installation  
Ceiling installation

### Versions:

Synchronisation and safety via synchronisation bar and toothed rack  
Self-supporting installation, without load on the bottom of the sub-casing

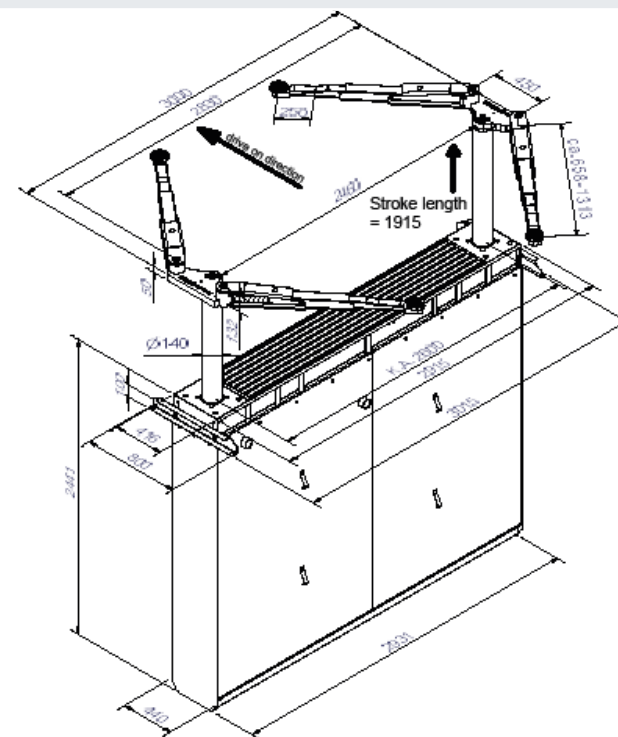

Masterlift 2.35 NxT Saa – H11 01 16 1A



# Masterlift 2.35 Combi Check-in PD 1550 MB

Electro-hydraulic twin-ram lift, 3.5 t with platforms and wheel-free device

The product meets the requirements for workshop equipment for MB service workshops and is recommended by Mercedes Benz with approval no. H12 01 04 1L

Masterlift 2.35 Combi Check-in – H12 01 04 1L

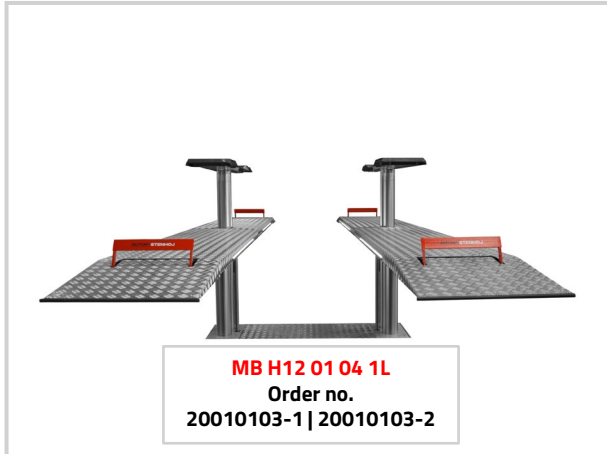

Order no.	Item no.	#	Part of the approval according to order no. 20010103-1/-2:
20010103-1	21500	1	Superstructure 2.35 F 440 Combi Check-in, on floor
	12466	1	Mercedes approval and painting, type Fn/Combi, grey RAL 7015
	12407	1	Extra charge zinc coated and painted platforms
	21080	1	Power distribution for one platform
	21097	1	Pneumatic installation for 1 side of the platform
	11102	1	Rubber blocks 40 mm, 1 set = 4 pcs.
	11103	1	Document holder AUTOPSTENHOJ
	11104	1	Magnetic tool tray set, 1 set = 2 pcs.
20010103-2	21504	1	Repair platform superstructure 2.35 Pv 160-220 xy
	10290	1	Hydraulic unit ML 2.35 Combi Check in PD 1550, stroke 1900 mm
	12036	1	Ecological hydraulic fluid 17 ltr.
	11109	1	16A circuit breaker in the control box
			<b>Not part of the approval (options)</b>
	11071	1	Set of cables 10 m
	12117	1	Cassette PD 1550, ML Combi Check in

The Masterlift 2.35 Combi Check-in PD is optimally suited for **quick and easy vehicle lifting**.

The platform is constructed of very strong and rigid **solid steel** that offers a **high degree of stability**. They are zinc coated and painted. Looks great and works great! Various lengths of repair platforms, which come with **xy-function in the premium version as standard**, make the Masterlift 2.35 NxT the perfect helper in your workshop.

Four **strong 123 mm diameter cylinders** are also designed for long-lasting functionality and further round off the high-quality level, which ensures **low maintenance requirements**.

Even in the event of a power blackout, the lift can still be lowered without any problems thanks to the pneumatic emergency lowering system.

The Masterlift Combi Check-in KA 1550 is perfectly completed by a **control system that is both visually and technically convincing**.

### Standard color:

Platforms: RAL 7015 and aluminium coated and integrated LED lighting

Pv Premium: zinc coated and painted RAL 7015

### Options:

XY-pads

Sets of rubber blocks, 40, 60, 80 and 100 mm

### Installation:

Superstructure on floor  
Superstructure recessed

### Steel cassette:

Standard: Primed

Optional: Hot-dip galvanised or plastic-coated

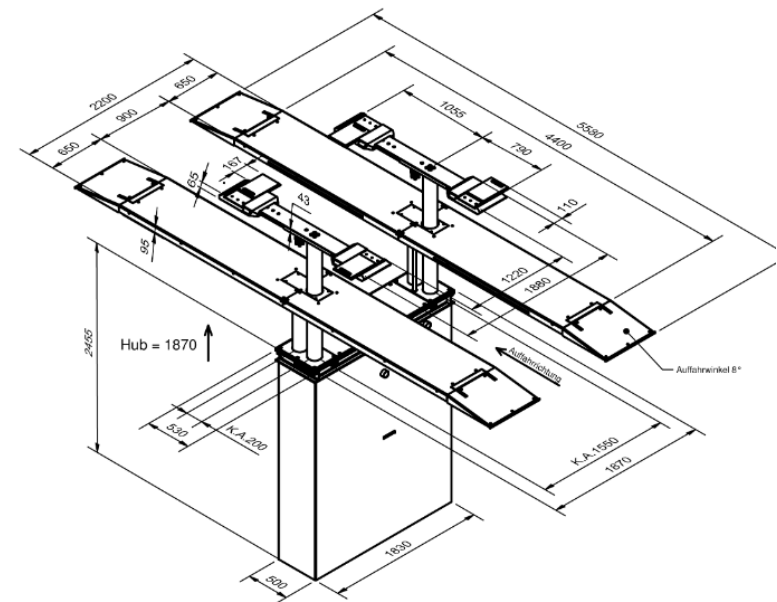



# Biglift 2.55 Saa 265 MB

Electro-hydraulic twin-ram lift, 5.5 t with superstructure with arms

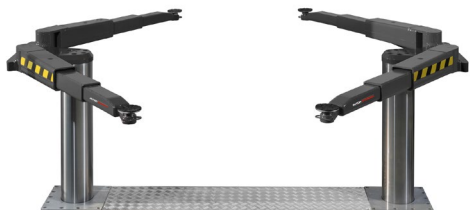

**MB H21 01 04 1B**  
Order no.  
20010104-1 | 20010104-2

Order no.	Item no.	#	Part of the approval according to order no. 20010104-1/-2:
20010104-1	21203	1	Superstructure BL 2.55 Saa 265 incl. lifting pad
	12172	1	M, mercedes approval and paint type: "S", RAL 7015 grey
	11103	1	Document holder AUTOPSTENHOJ
	11104	1	Magnetic tool tray set, 1 set = 2 pcs.
20010104-2	10309	1	Hydraulic unit BL 2.55, Ø213, PD 2650, stroke 1860 mm
	12036	1	Ecological hydraulic fluid 17 ltr.
			<b>Not part of the approval (options)</b>
	11063	1	Set of cables 10 m
	12106	1	Cassette PD 2650 BL

The double telescopic swivel arms convince with a **non-standard lifting area**, which even makes it possible to lift commercial vehicles and large cars without any problems.

The **internal arm locking system** installed as standard reliably protects against external influences. An integrated mechanical safety ratchet provides additional safety for all work processes.

The **strong 213 mm diameter cylinders** are also designed for long-lasting functionality and further round off the high-quality level, which ensures **low maintenance requirements**.

Even in the event of a power blackout, the lift can still be lowered without any problems thanks to the pneumatic emergency lowering system.

The Biglift 2.55 Saa 265 is perfectly completed by a **control system that is both visually and technically convincing**.

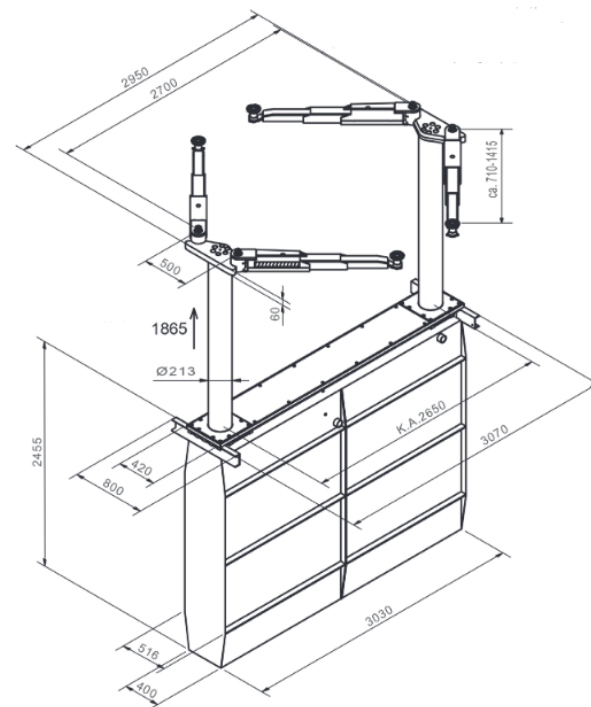

**Standard color:**  
RAL 7015

**Option:**  
Large program of extra pads, depending on type of vehicle

**Installation:**  
Superstructure on floor  
Superstructure recessed with covers  
Ceiling installation

**Steel cassette:**  
Standard: Primed  
Optional: Hot-dip galvanised or plastic-coated

The product meets the requirements for workshop equipment for MB service workshops and is recommended by Mercedes Benz with approval no. H21 01 04 1B.

Biglift 2.55 Saa 265 – H21 01 04 1B



# Biglift 2.65 Saaa 265 MB

Electro-hydraulic twin-ram lift, 6.5 t with superstructure with arms

The product meets the requirements for workshop equipment for MB service workshops and is recommended by Mercedes Benz with approval no. H21 01 04 1A

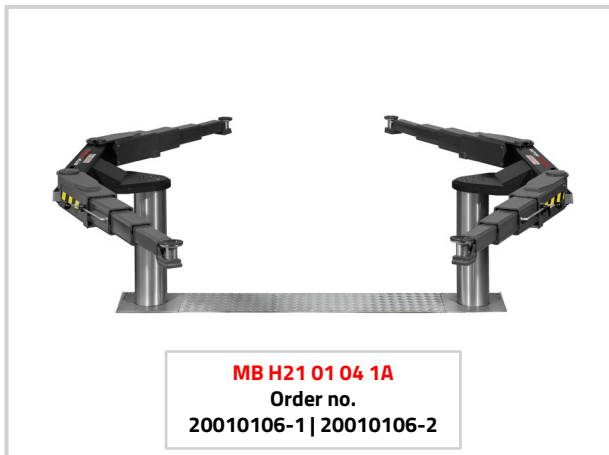

**MB H21 01 04 1A**  
Order no.  
**20010106-1 | 20010106-2**

Order no.	Item no.	#	Part of the approval according to order no. 20010106-1/-2:
20010106-1	21210	1	Superstructure BL 2.65 Saaa 265 incl. lifting pads
	12172	1	M, Mercedes-approval and painting - S - grey RAL 7015
	11103	1	Document holder AUTOPSTENHOJ
	11104	1	Magnetic tool tray set, 1 set = 2 pcs.
20010106-2	10287	1	Hydraulic unit BL 2.65, Ø213, PD 2650, stroke 1860 mm
	12036	1	Ecological hydraulic fluid 17 ltr.
			<b>Not part of the approval (options)</b>
	11063	1	Set of cables 10 m
	12106	1	Cassette PD 2650 BL

The triple telescopic swivel arms convince with a **non-standard lifting area**, which even makes it possible to lift commercial vehicles and large cars without any problems.

The **internal arm locking system** installed as standard reliably protects against external influences. An integrated mechanical safety ratchet provides additional safety for all work processes.

The **strong 213 mm diameter cylinders** are also designed for long-lasting functionality and further round off the high-quality level, which ensures **low maintenance requirements**. Even in the event of a power blackout, the lift can still be lowered without any problems thanks to the pneumatic emergency lowering system.

The Biglift 2.65 Saaa 265 is perfectly completed by a **control system that is both visually and technically convincing**.

**Standard color:**  
RAL 7015 grey

**Options:**  
Large program of extra pads, depending on type of vehicle

**Installation:**  
Superstructure on floor  
Superstructure recessed with covers  
Ceiling installation

**Steel cassette:**  
Standard: Primed  
Optional: Hot-dip galvanised or plastic-coated

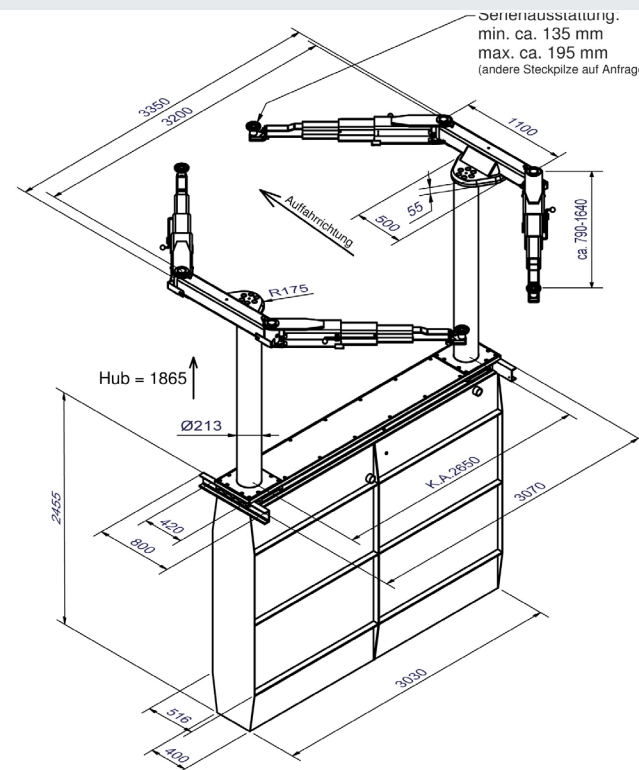



# Biglift 2.65 F 550 MB

Electro-hydraulic twin-ram lift, 6.5 t with platforms

The product meets the requirements for workshop equipment for MB service workshops and is recommended by Mercedes-Benz with approval no. H23 13 10 7A.



**MB H23 13 10 7A**  
Order no.  
**20010107-1 | 20010107-2**

Order no.	Item no.	#	Part of the approval according to order no. 20010107-1/-2:
20010107-1	21507	1	Superstructure BL 2.65 F 550
	21100	1	Drive-on ramp, on floor, 1100 mm, 10°, 1 set = 2 pcs.
	21084	1	Roll-off safety device, h = 100 mm, 1 set = 2 pcs.
	12465	1	M, Mercedes-approval and painting - type F - grey RAL 7015
	12407	1	Extra charge zinc coated and painted platforms
	21080	1	Power distribution for one platform
	21096	1	Pneumatic installation for 1 side of the platform
	11103	1	Document holder AUTOPSTENHOJ
	11104	1	Magnetic tool tray set, 1 set = 2 pcs.
	21093	1	Jacking beam A air hydr. 4 t, incl. innovative air supply, suspension BL 2.65 F
	12468	1	M, Mercedes-approval and painting - scissor jack 4.0 t, RAL 7015
20010107-2	12925	1	Lifting pad adapter for jacking beam
	11027	2	Pad Ø120/95/135
	10291	1	Hydraulic unit BL 2.65 - 1550, cylinder Ø213, stroke 1860
	12036	1	Ecological hydraulic fluid 17 ltr.
	11109	1	16A circuit breaker in the control box
	11063	1	Set of cables 10 m
	12173	1	Cassette BL PD 1550

The Biglift 2.65 F 550 repair platform is optimally suited for **quick and easy vehicle lifting**.  
 The premium version is constructed of very strong and rigid **solid steel** that offers a **high degree of stability**.  
 They are zinc coated and painted. Looks great and works great!  
 Two **strong 213 mm diameter cylinders** are also designed for long-lasting functionality and further round off the high-quality level, which ensures **low maintenance requirements**.  
 Even in the event of a power blackout, the lift can still be lowered without any problems thanks to the pneumatic emergency lowering system.  
 The Biglift 2.65 F 550 is perfectly completed by a **control system that is both visually and technically convincing**.

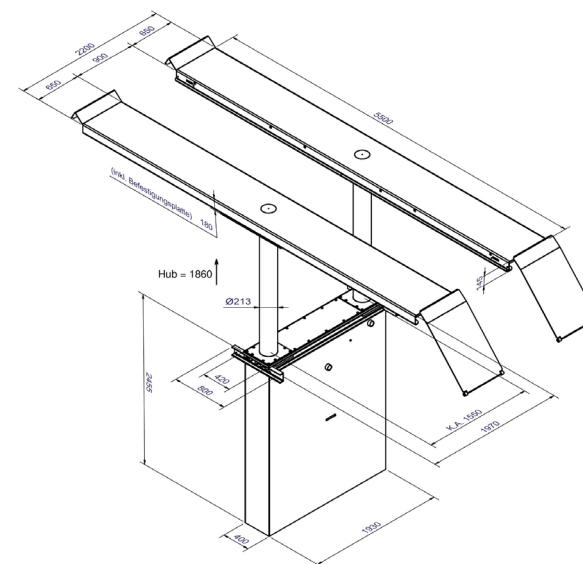

**Standard color:**  
RAL 7015 grey

**Options:**  
LED lighting set  
Scissor jacks

**Installation:**  
Superstructure on floor  
Superstructure recessed

**Steel cassette:**  
Standard: Primed  
Optional: Hot-dip galvanised or plastic-coated





# Biglift 4.55 Combi MB

Electro-hydraulic 4-ram lift, 5.5 t with platforms and free-wheel lift with arms



**MB H22 13 10 7A**  
Order no.  
**20010105-1 | 20010105-2**

Bestell-Nr.	Art.-Nr.	#	Part of the approval according to order no. 20010105-1/-2:
20010105-1	21509	1	Superstructure BL 4.55 Fn 550 Combi, on floor
	21205	1	Superstructure BL 4.55 Saav 155 Combi incl. lifting pads
	21100	1	Drive-on ramp, on floor, 1100 mm, 10°, 1 set = 2 pcs.
	21084	1	Roll-off safety device, h = 100 mm, 1 set = 2 pcs.
	12465	1	M, Mercedes-approval and painting - F - grey RAL 7015
	12172	1	M, Mercedes-approval and painting - S - grey RAL 7015
	12407	1	Extra charge zinc coated and painted platforms ML, PL, BL
	21080	1	Power distribution for one platform
	21096	1	Pneumatic installation for 1 side of the platform
	11103	1	Document holder AUTOPSTENHOJ
20010105-2	11104	1	Magnetic tool tray set, 1 set = 2 pcs.
	10295	1	Hydraulic unit BL 4.55 Combi, PD 1240, stroke 1850 mm
	12038	1	Ecological hydraulic fluid 20 ltr.
	11109	1	16A circuit breaker in the control box
			<b>Not part of the approval (options)</b>
	11071	1	Set of cables 10 m
	12245	1	Cassette BL Combi, 5,5 t

Die Biglift 4.55 Combi repair platform is optimally suited for **quick and easy vehicle lifting**.

The premium version is constructed of very strong and rigid **solid steel** that offers a **high degree of stability**.

They are zinc coated and painted. Looks great and works great!

The additional swivel arm superstructures, **as standard equipped with double telescopic and transversely moveable swivel arms**, make the Biglift 4.55 Combi the perfect helper in your workshop.

Four strong 2x123 mm diameter double cylinders are also designed for long-lasting functionality and further round off the high-quality level, which ensures **low maintenance requirements**.

Even in the event of a power blackout, the lift can still be lowered without any problems thanks to the pneumatic emergency lowering system.

The Biglift 4.55 Combi is perfectly completed by a **control system that is both visually and technically convincing**.

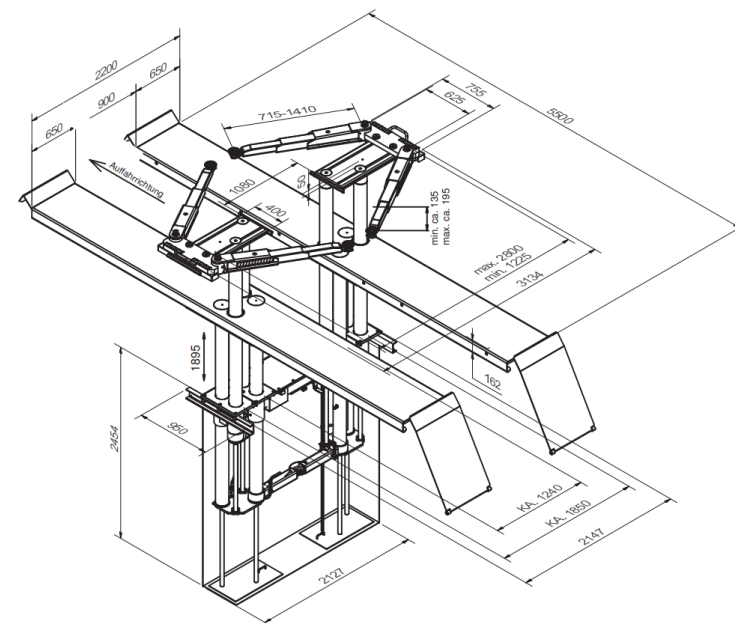

### Standard color:

RAL 7015 grey

### Installation:

Superstructure on floor

Superstructure recessed, with or without flush floor device

### Steel cassette:

Standard: Primed

Optional: Hot-dip galvanised or plastic-coated

### Options:

Large program of extra pads depending on type of vehicle

LED lighting set



# Sharklift 4.65 F 550 MB

Electro-hydraulic 4-ram lift, 6.5 t, with platforms

The product meets the requirements for workshop equipment for MB service workshops and is recommended by Mercedes-Benz with approval no. H41 01 08 1P



**MB H41 01 08 1P**  
Order no.  
**20010108-1 | 20010108-2**

Order no.	Item no.	#	Part of the approval according to order no. 20010108-1/-2:
20010108-1	21072	1	Superstructure SHL 4.65 F 550 - KA 1550/3000
	21095	1	Long drive-on ramps 1400 mm, 8° (1 Set = 2 pcs.) 4.65
	21116	1	Roll-off safety device QL 4.55 / 4.65, 1 Set = 2 pcs.
	12465	1	M, Mercedes-approval and painting - F - grey RAL 7015
	12420	1	Extra charge for spray-galvanized platforms QL 4.65
	21080	1	Power distribution for one platform
	21081	1	Pneumatic installation QL 4.65 for 1 side of the platform
	11103	1	Document holder AUTOPSTENHOJ
	11104	1	Magnetic tool tray set, 1 set = 2 pcs.
	20549	2	Sliding plates MB version (1 set = 2 pcs.)
	21075	1	Jacking beam A air hydr. 4 t, incl. innovative air supply, suspension SHL 4.65
	12468	1	M, Mercedes-approval and painting - scissor jack 4.0 t, RAL 7015
	12925	1	Lifting pad adapter for jacking beam
20010108-2	11027	2	Pad Ø120/95/135
	21076	1	MKS console cpl. rotatable, MB-version
	10293	1	Hydraulic unit SHL 4.65 Cyl. Ø 213, stroke 1865 mm, PD 1550/3000
	12042	1	Ecological hydraulic fluid, 24 ltr.
	11073	1	Set of cables QL 4.65
	12310	1	Set of cassettes SHL PD 1550/3000

The Sharklift 4.65 F 550 repair platform is optimally suited for **quick and easy wheel alignment**. The platform is constructed of very strong and rigid **solid steel** that offers a **high degree of stability**. They are zinc coated and painted. Looks great and works great!

The Sharklift 4.65 F 550 also impresses with its enormous precision! Four **strong 213 mm diameter cylinders** and **four mechanical safety ratchets** are also designed for long-lasting functionality and further round off the high-quality level, which ensures **low maintenance requirements**.

The Sharklift 4.65 F 550 is perfectly completed by a **control system that is both visually and technically convincing**.

**Standard color:**  
RAL 7015 grey

**Options:**  
LED lighting set  
Scissor jacks  
Precision sliding plates

**Installation:**  
Superstructure on floor  
Superstructure recessed, with or without flush-floor device

**Steel cassette:**  
Standard: Primed  
Optional: Hot-dip galvanized or plastic-coated

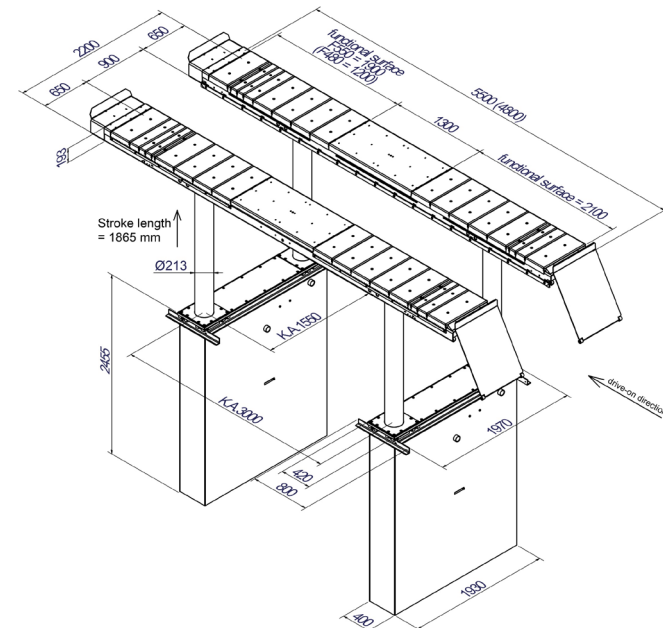



# Maestro 2.35 NxT MB

Electro-mechanical 2-post lift with 3.5 t capacity

The product meets the requirements for workshop equipment for MB service workshops and is recommended by Mercedes Benz with approval no. 098474

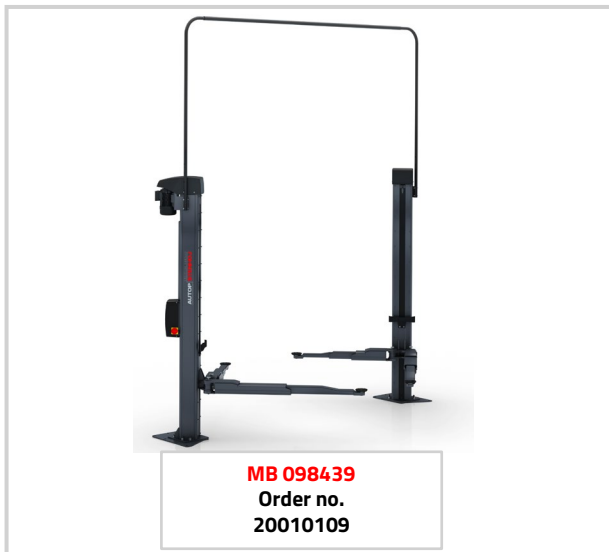

**MB 098439**  
**Order no.**  
**20010109**

Order no.	Item no.	#	Part of the approval according to order no. 20010109:
20010109	98470	1	Maestro 2.35 NxT F
	777958	1	Portal connection kit (4060), Maestro 2.35 NxT F (H: 1675 mm)
	777449	1	Set, expansion bolts, 14 x HST3 M16x170 70/50
	11103	1	Document holder AUTOPSTENHOJ
	11104	1	Magnetic tool tray set, 1 set = 2 pcs.

The 2-post lifts of the Maestro 2.xx series impress with their premium construction. They come with **extremely stable and welded columns**. Smooth running behaviour is ensured by the **roller-bearing carriage**. The **cold-rolled spindle** guarantees a **particularly long service life**. The columns are asymmetrically positioned, i.e. vehicles can be positioned far to the rear, which ensures an **optimal door opening angle**. Of course, the Maestro 2.35 NxT also has a door stop protection to prevent damage during entry and exit. The **swivel arms are extremely flat** and thus ensure a **low minimum height**. The **internal arm locking system** with strong 360° interlocking protects against moisture and dirt.

**Standard color:**  
Arms: RAL 7015  
Posts: RAL 7015

**Versions:**  
Available for different voltages  
F = flex pad

**Options:**  
Available with different portal heights, alternatively inground kit  
LED lighting set  
Energy set with compressed air and socket-outlet  
Set of expansion bolts  
Extra control unit for second column  
Wheel support devices  
Large program of extra pads, depending on type of vehicle

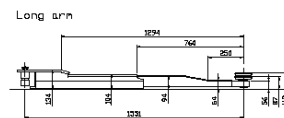
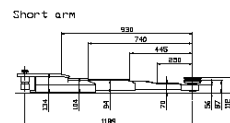
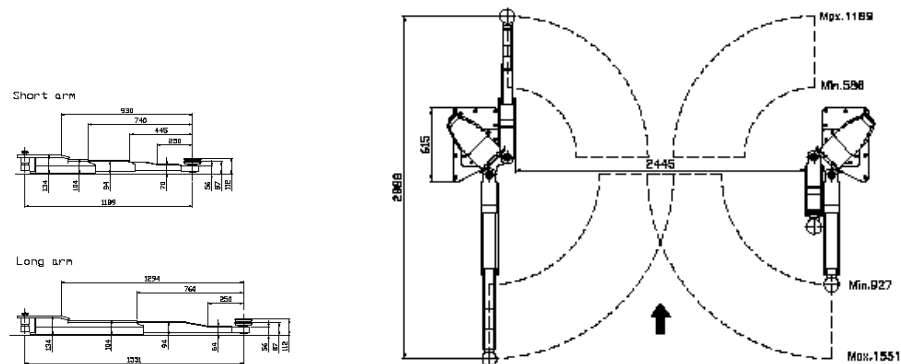
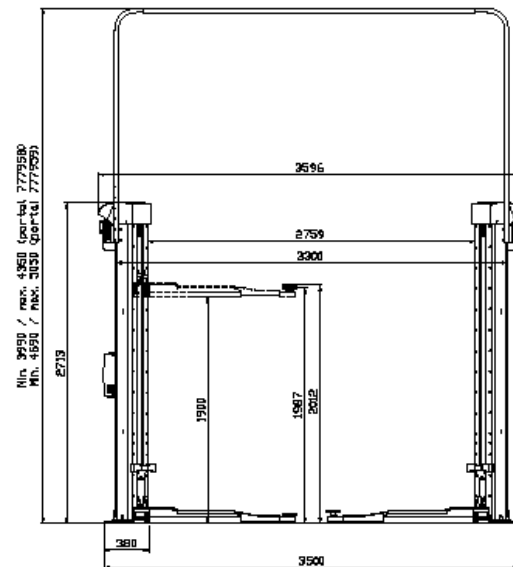



# Maestro 2.65 MB

Electro-mechanical 2-post lift with 6.5 t capacity

The product meets the requirements for workshop equipment for MB service workshops and is recommended by Mercedes Benz with approval no. H21 01 06 1L.

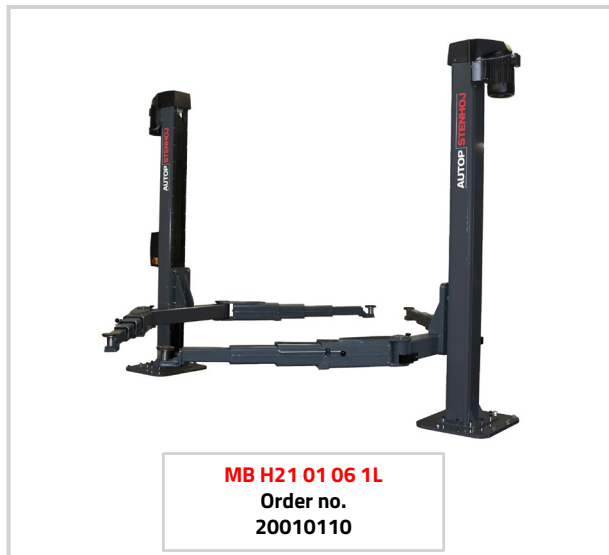

**MB H21 01 06 1L**  
**Order no.**  
**20010110**

Order no.	Item no.	#	Part of the approval according to order no. 20010110:
20010110	098220	1	Maestro 2.65 F
	777414	1	Portal connection kit for Maestro 2.65 F
	777255	1	Set, expansion anchor bolts, 18 x HST3-R M20x170 -/30
	11103	1	Document holder AUTOPSTENHOJ
	11104	1	Magnetic tool tray set, 1 set = 2 pcs.

The 2-post lifts of the Maestro 2.xx series impress with their premium construction.

They come with **extremely stable and welded columns**.

Smooth running behaviour is ensured by the **roller-bearing carriage**.

The **cold-rolled spindle** guarantees a **particularly long service life**.

The welded and symmetrically installed posts are perfectly suited for lifting **large and heavy vehicles up to 6.5 t at maximum**. Through its **unique columns** the Maestro 2.65 has not only the **strongest, but slimmest post available on the market**. Due to its special swivel arm construction with cross beam the Maestro 2.65 is appropriate for a wide car park.

**Maximum safety with optimum access to the vehicle!**

### Standard color:

Arms: RAL 7015  
posts: RAL 7015

### Versions:

Available with different voltages  
F = flex pad

### Options:

- Available with portal or in-ground kit
- LED lighting set
- Power pack
- Set of expansion bolts
- Extra control unit
- Wheel support devices
- Large program of extra pads depending on type of vehicle

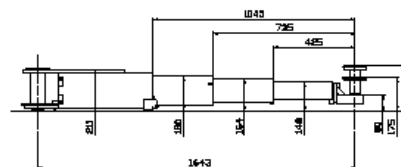
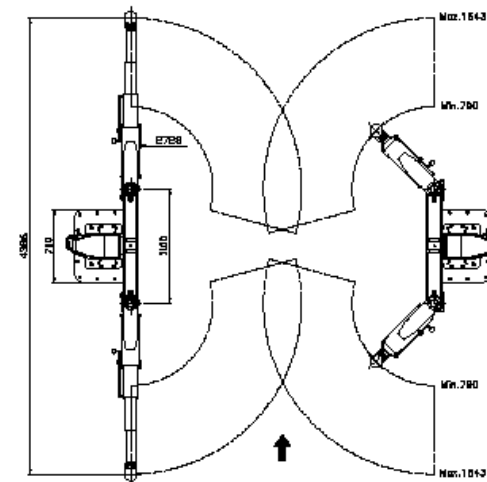
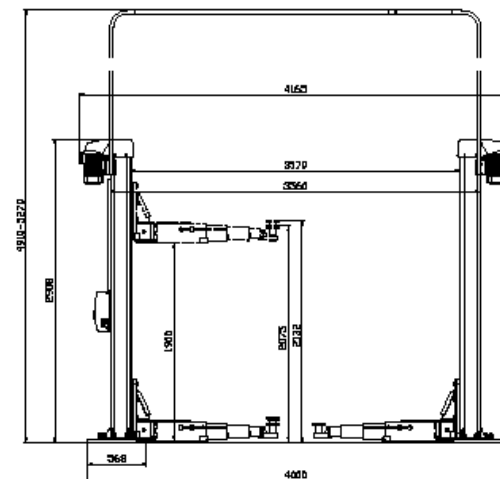



AUTOPSTENHOJ GmbH | Sandkampstr. 90 | D-48432 Rheine  
Tel. 0049 5971 8602-02 | E-Mail: [info@autopstenhoj.com](mailto:info@autopstenhoj.com)