

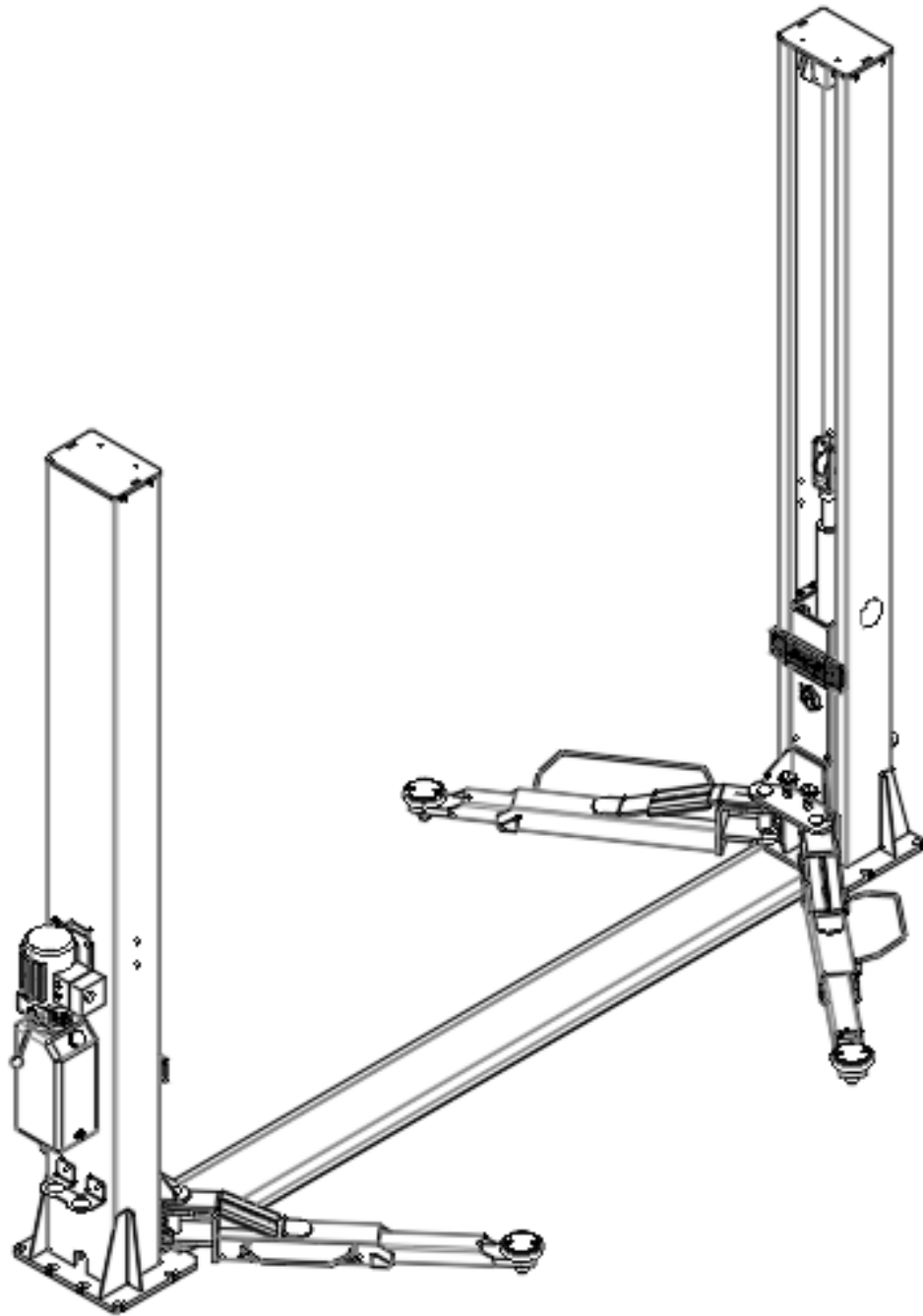



Installation, Operating and Service Manual



PRINTING CHARACTERS AND SYMBOLS

Throughout this manual, the following symbols and printing characters are used to facilitate reading:

	Indicates the operations which need proper care
	Indicates prohibition
	Indicates a possibility of danger for the operators
	Indicates the direction of access for motor vehicles to the lift
GRASSETTO	Important information



WARNING: before operating the lift and carrying out any adjustment, read carefully chapter 4 "Installation" where all proper operations for a better functioning of the lift are described..

INDEX

GENERAL INFORMATION	5
1 – TECHNICAL DATA	7
1.1 LIFT DESCRIPTION.....	8
1.2 LAYOUT	9
1.3 LOAD DISTRIBUTION.....	10
1.4 PICTOGRAMS	11
1.4 PICTOGRAMS APPLICATION DIAGRAM.....	错误!未定义书签。
1.5 HAZARDOUS AREAS	12
2 - FOREWORD	13
2.1 EC CERTIFICATION	13
2.2 TESTING.....	13
3 - GENERAL SAFETY AND ACCIDENT-PREVENTION RULES	14
3.1 SET-UP AND CLOTHING.....	15
3.2 ENVIRONMENT AND POLLUTION.....	15
3.3 LIFT SCRAPPING	15
3.3 DANGER LEVELS.....	15
3.5 HAZARDOUS AREAS	16
3.6 IDENTIFICAZIONE DEL SOLLEVATORE E DESCRIZIONE PITTOGRAMMI	16
3.7 INTENDED USE.....	16
4 – TRANSPORT AND INSTALLATION	17
4.1 UNPACKING	17
4.2 INSTALLATION AREA	18
4.3 INSTALLATION	19
4.4 CONNECTING TO THE ELECTRICITY MAINS	20
4.5 ELECTRICAL HOOK UP ON THE CONTROL PANEL.....	错误!未定义书签。
4.6 ELECTRICAL HOOK UP BETWEEN THE TWO PILLARS.....	错误!未定义书签。
4.7 HYDRAULIC CONNECTION.....	21
4.8 CONNECTION CABLES OF SYNC.....	22
5.1 START UP.....	23
5.1.2 ADJUSTMENT OF THE LIFTING TIME FOR RELEASE OF THE SAFETY LOCKS	错误!未定义书签。
5.2 UTILIZATION.....	23
5.3 EMERGENCY PROCEDURES	25
WARNING	26
6 - MAINTENANCE	26

BEFORE STARTING TO OPERATE WITH THE BRIDGE READ CAREFULLY THE INSTRUCTIONS CONTAINED IN THIS MANUAL

THIS USER'S MANUAL IS WRITTEN IN THE MANUFACTURER'S LANGUAGE, AND IN OTHER COMMUNITY LANGUAGES. IN CASE OF COMPLAINT, FOR LEGAL PURPOSES, THE VERSION IN ITALIAN LANGUAGE ONLY WILL APPLY. THE MANUFACTURER DISCLAIMS ANY LIABILITY FOR DIRECT AND/OR INDIRECT DAMAGES CAUSED BY POOR TRANSLATION OR WRONG TEXT INTERPRETATION.

WARRANTY

The manufacturer warrants lifts and the relevant accessories for 12 months after purchase date. This warranty consists in the repair or replacement - free of charge - of those parts that, after a careful analysis by the Manufacturer's Technical Service, turn out to be faulty from origin. All electrical parts are excluded. Warranty is limited to material defects, and becomes null and void if the returned parts are tampered with or disassembled by unauthorized staff. Any liability for direct and indirect injuries to people, animals or property due to machine failure or malfunction are excluded from warranty. The expenses deriving from lubricants replacement, transport charges, and any customs duty, VAT and any other expense not specified in the supply contract are at the purchaser's charge. The replacement and repair of parts under warranty, anyway, do not extend warranty terms. The purchaser will nevertheless be entitled to assert its rights on warranty, specified in the supply contract. Should the parties not be willing to submit any dispute arising from the supply contract to arbitration, or in any other case where the judgement of a body of the ordinary competent court is required, the Court of Reggio Emilia will be the only competent court on the territory.

DISCLAIMER

Upon delivery, please check that the product has not been damaged during transportation, and that the accessories coming with it are intact and complete. Any complaint on Product appearance shall be filed within 8 days after lift delivery date. Besides the cases envisaged by the supply contract, the warranty becomes null and void:

- In case of a maneuver error caused by the operator.
- If the damage is caused by poor maintenance.
- If the envisaged capacity is exceeded.
- If the machine has been somehow modified, and the damage has been caused by such a modification, due to repair operations by the user without the authorization of the manufacturer or after fitting non-original spare parts.
- If the instructions described in the user's manual are not complied with.

GENERAL INFORMATION

This chapter contains warning instructions to properly operate the lift and prevent injury to operators or property. This manual has been written to be used by workshop technicians in charge of the lift (OPERATOR) and routine maintenance technician (MAINTENANCE OPERATOR). The operating instructions are considered to be an integral part of the machine and must remain with it for its whole useful life. Read every section of this manual carefully before operating the lift and unpacking, since it gives helpful information about:

- SAFETY OF PEOPLE
- SAFETY OF THE LIFT
- SAFETY OF LIFTED VEHICLES

The company is not liable for possible problems, damage, accidents, etc. resulting from failure to follow the instructions contained in this manual.

Only skilled technicians of AUTHORIZED DEALERS or SERVICE CENTRES AUTHORIZED by the manufacturer shall be allowed to carry out lifting, transport, assembling, installation, adjustment, calibration, settings, extraordinary maintenance, repairs, overhauling and dismantling of the lift.

The manufacturer is not responsible for possible damage to people, vehicles or objects if said operations are carried out by unauthorized personnel or if the lift is improperly used.

Any use of the machine made by operators who are not familiar with the instructions and procedures contained herein shall be forbidden.

MANUAL KEEPING

For a proper use of this manual, the following is recommended:

- Keep the manual near the lift, in an easily accessible place.
- Keep the manual in an area protected from damp.
- Use this manual properly without damaging it.
- Do not make any changes to this manual; any modifications and updates shall be made by the supplying company only.

This manual is an integral part of the lift: it shall be given to the new owner if and when the lift is resold.

OBLIGATIONS IN CASE OF MALFUNCTION



In case of machine malfunction, follow the instructions contained in the following chapters.

CAUTIONS FOR THE SAFETY OF THE OPERATORS

Operators must not be under the influence of sedatives, drugs or alcohol when operating the machine.



Before operating the lift, operators must be familiar with the position and function of all controls, as well as with the machine features shown in chapter "Operation and use".

WARNINGS



Unauthorized changes and/or modifications to the machine relieve the manufacturer from any liability for possible damage to objects or people. Do not remove or make inoperative the safety devices, this would cause a violation of law and regulations on safety at work.



Any other use which differs from that provided for by the manufacturer of the machine is strictly forbidden.



The use of non-original parts may cause damage to people or objects.

DECLARATION OF WARRANTY AND LIMITATION OF LIABILITY

The manufacturer has paid proper attention to the preparation of this manual. However, nothing contained herein modifies or alters, in any way, the terms and conditions of the manufacturer agreement by which this lift was purchased, nor increases, in any way, manufacturer's liability towards the customer.

TO THE READER

Every effort has been made to ensure that the information contained in this manual is correct, complete and updated. The manufacturer is not liable for any mistakes made when drawing up this manual and reserves the right to make any changes required due to the development of the product, at any time.

1 – TECHNICAL DATA

Max. capacity	Kg	4000	
Lifting time when loaded	s	40	
Lowering time when loaded	s	40	
Minimum height	mm	98	
Lifting height	mm	1900	
Distance between the columns	mm	2800	
Lift max. height	mm	2818	
Three-phase electric motor	Volt-Hz-Amp	380V/50Hz	
Three-phase motor power	kW/HP	2.2/4	
Single-phase electric motor	Volt-Hz-Amp	220V /50Hz	
Single-phase motor power	kW/HP	2.2/4	
Max. operating hydraulic pressure	Bar	230	
Total weight of lift	Kg	595	
Package size (for shipment)	mm	2900x460x700; 770x260x290	
Recommended hydraulic oil	Tipo	ISO VG32	
Hydraulic system oil quantity	Lt	9	
Fixing to the floor with screw anchors	N°10	GB22795-M18×160-JD	
Average sound level at the operator's workstation LpA	dB(A)	72	



THE LIFTER IS SUPPLIED STANDARD WITH 380V-3PH-50HZ POWER SUPPLY. ONLY ON REQUEST, IT CAN BE SUPPLIED WITH DIFFERENT ELECTRIC POWER SUPPLY.

1.1 LIFT DESCRIPTION

DESCRIPTION OF THE LIFT

1. P1 Column
2. P2 Column
3. P1 Carriage
4. P2 Carriage
5. cover
6. 2 Stage long lifting arm
7. 2 Stage short lifting arm
8. Cable passage cover
9. Electric motor
10. Oil cylinder
11. chain
12. cable
13. Hydraulic power unit
14. height limit switch

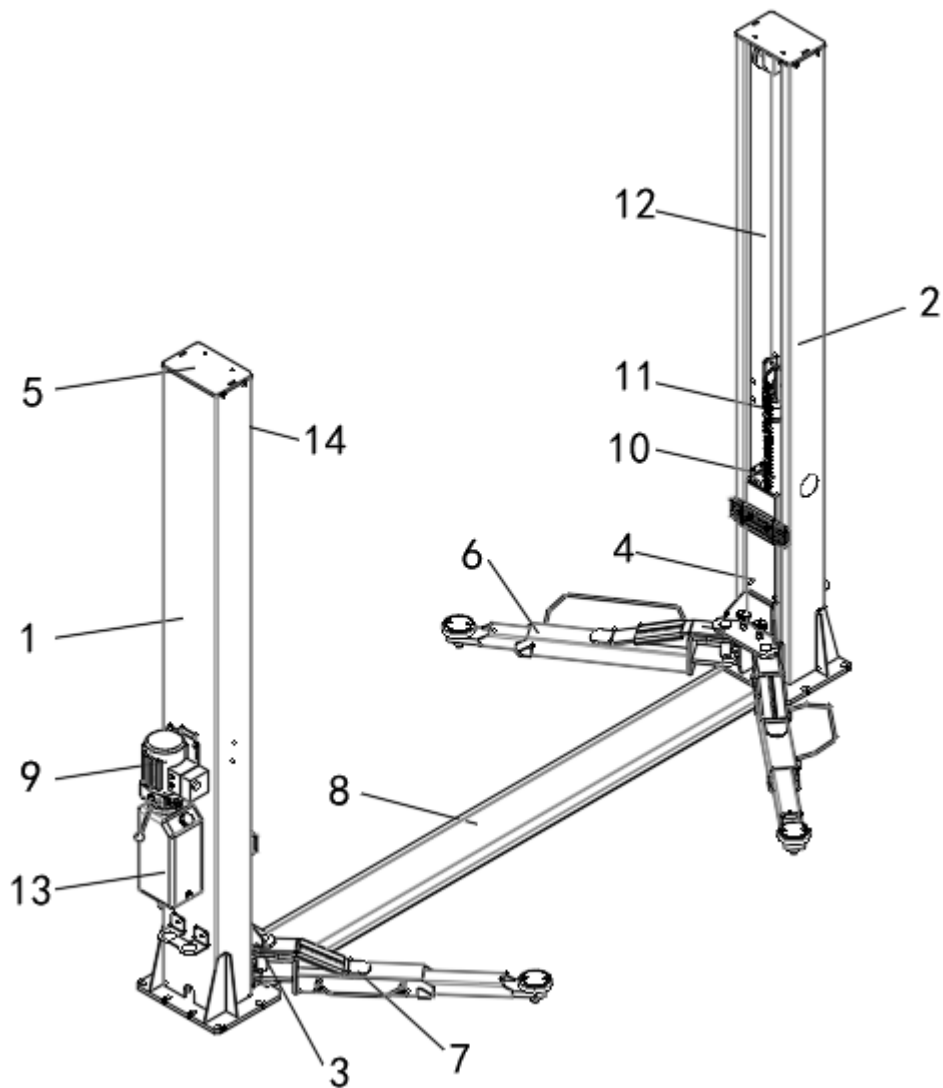

1.2 LAYOUT

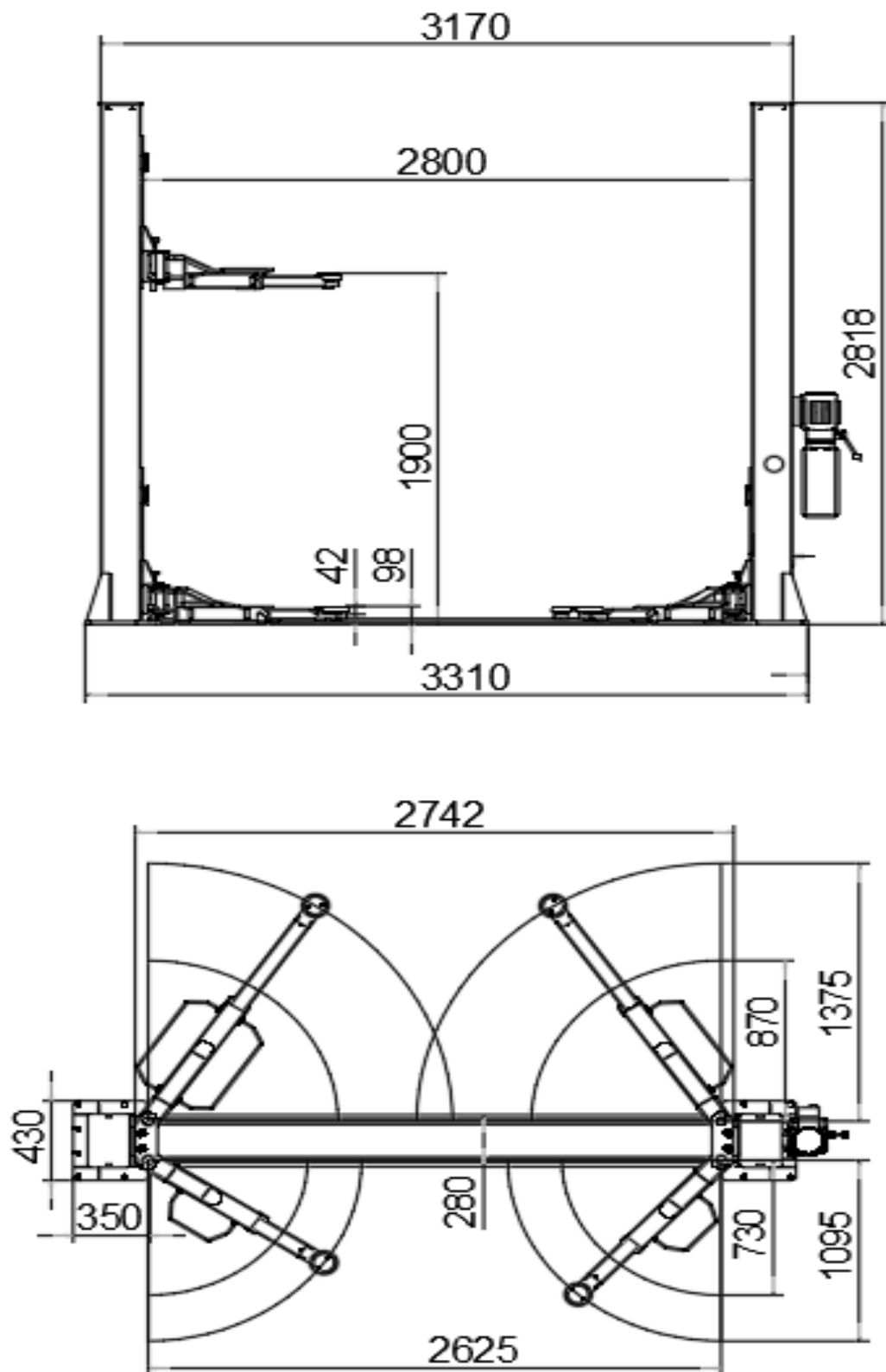

1.3 LOAD DISTRIBUTION

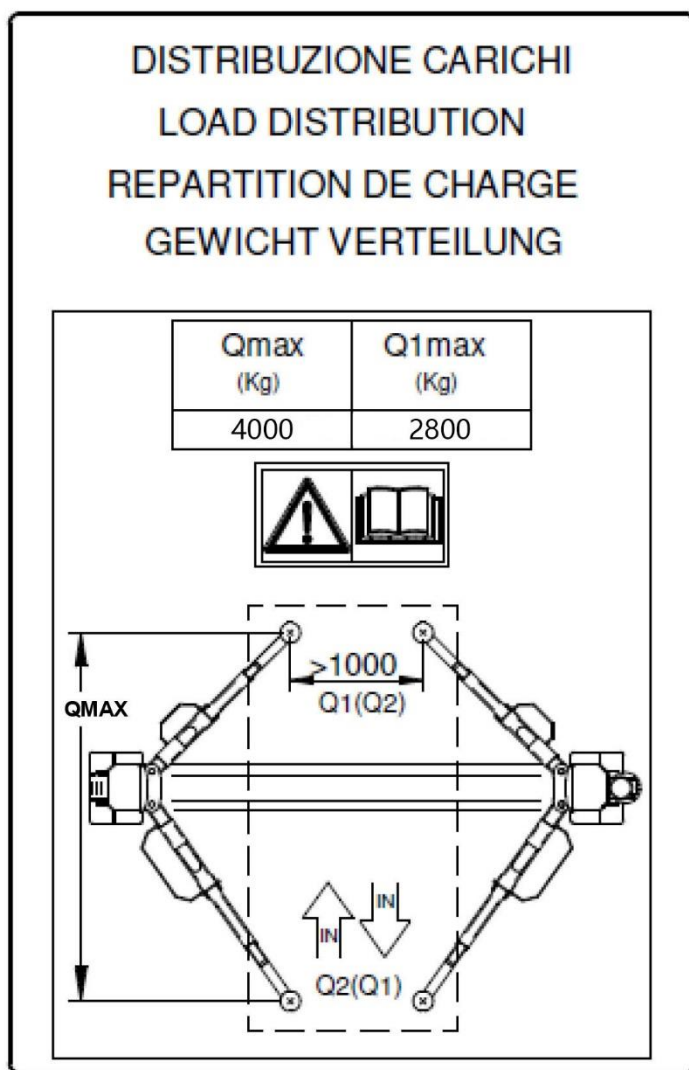

400V (Y)

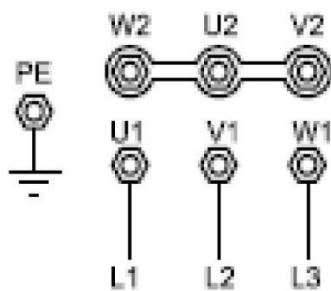

230V (Δ)

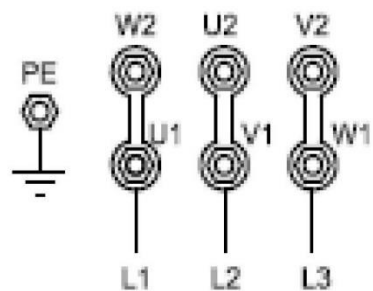

Fig. 4

1.4 PICTOGRAMS

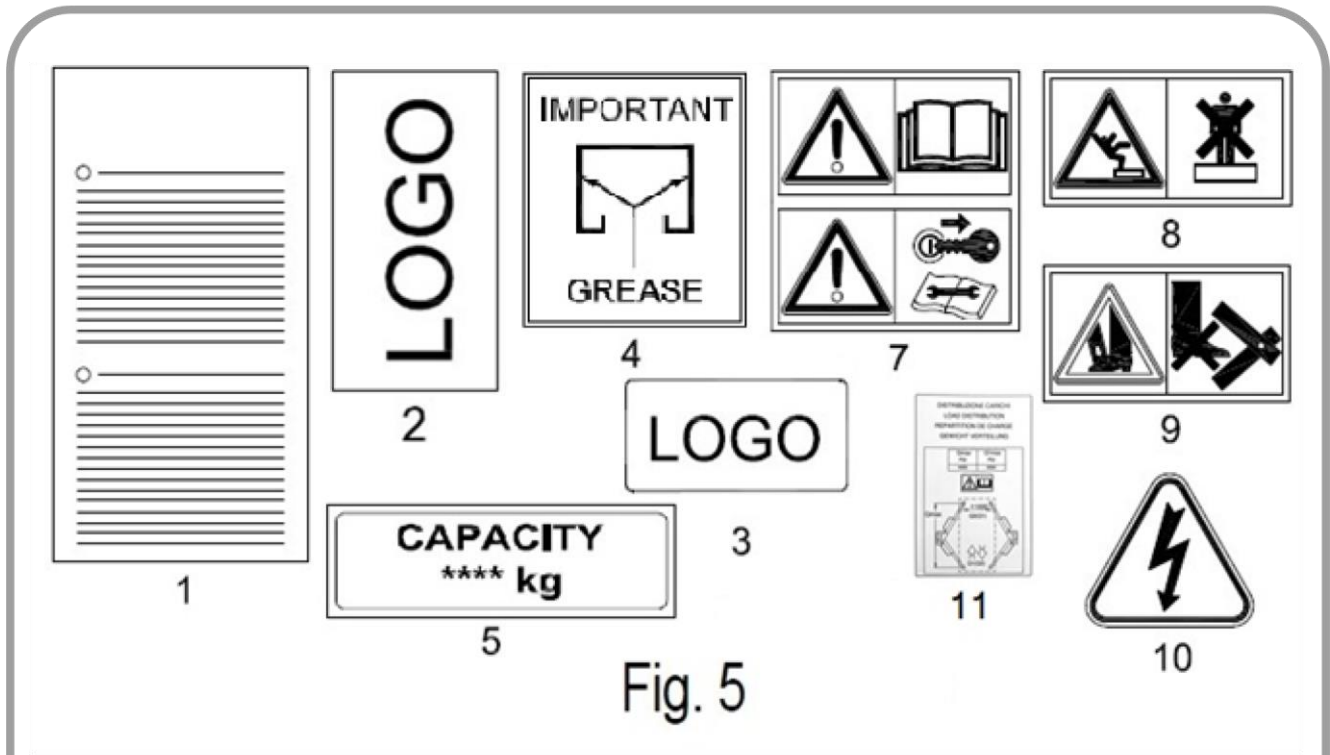
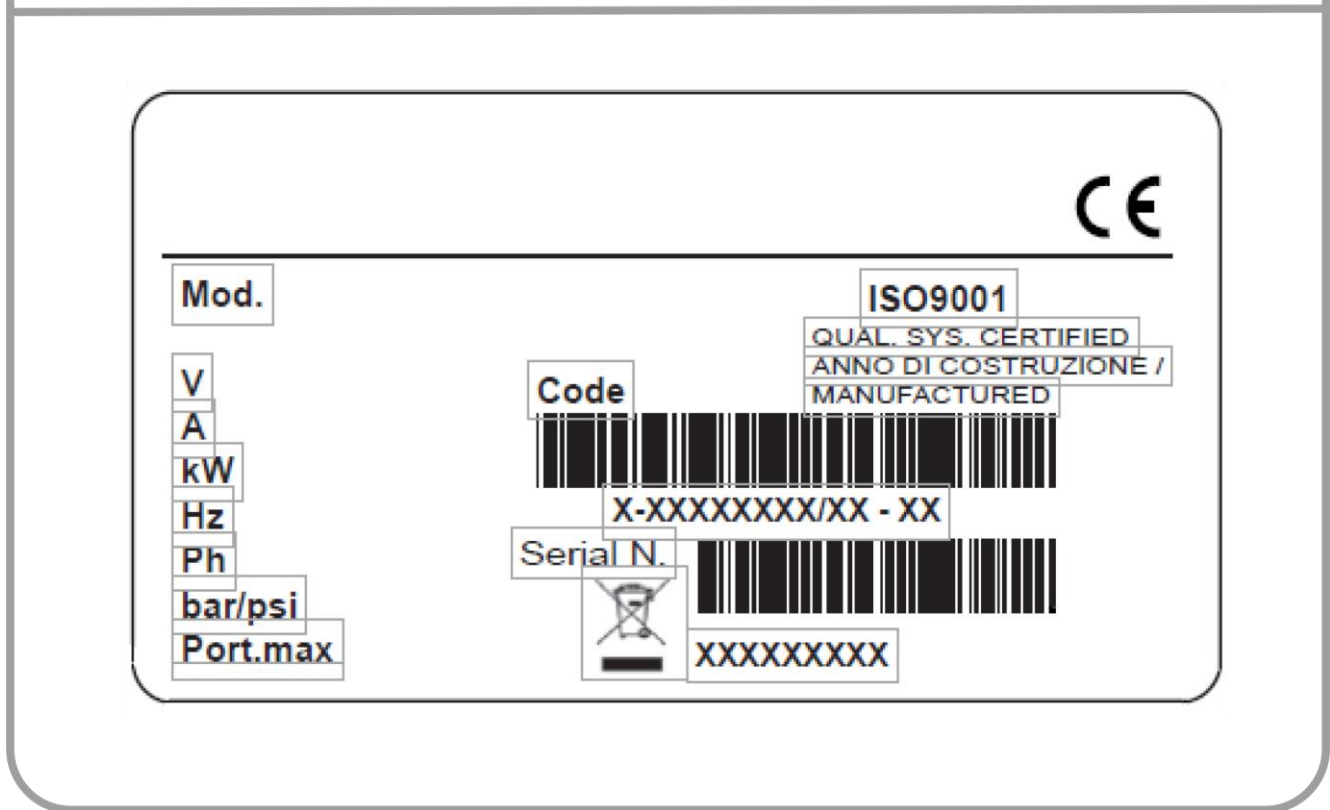
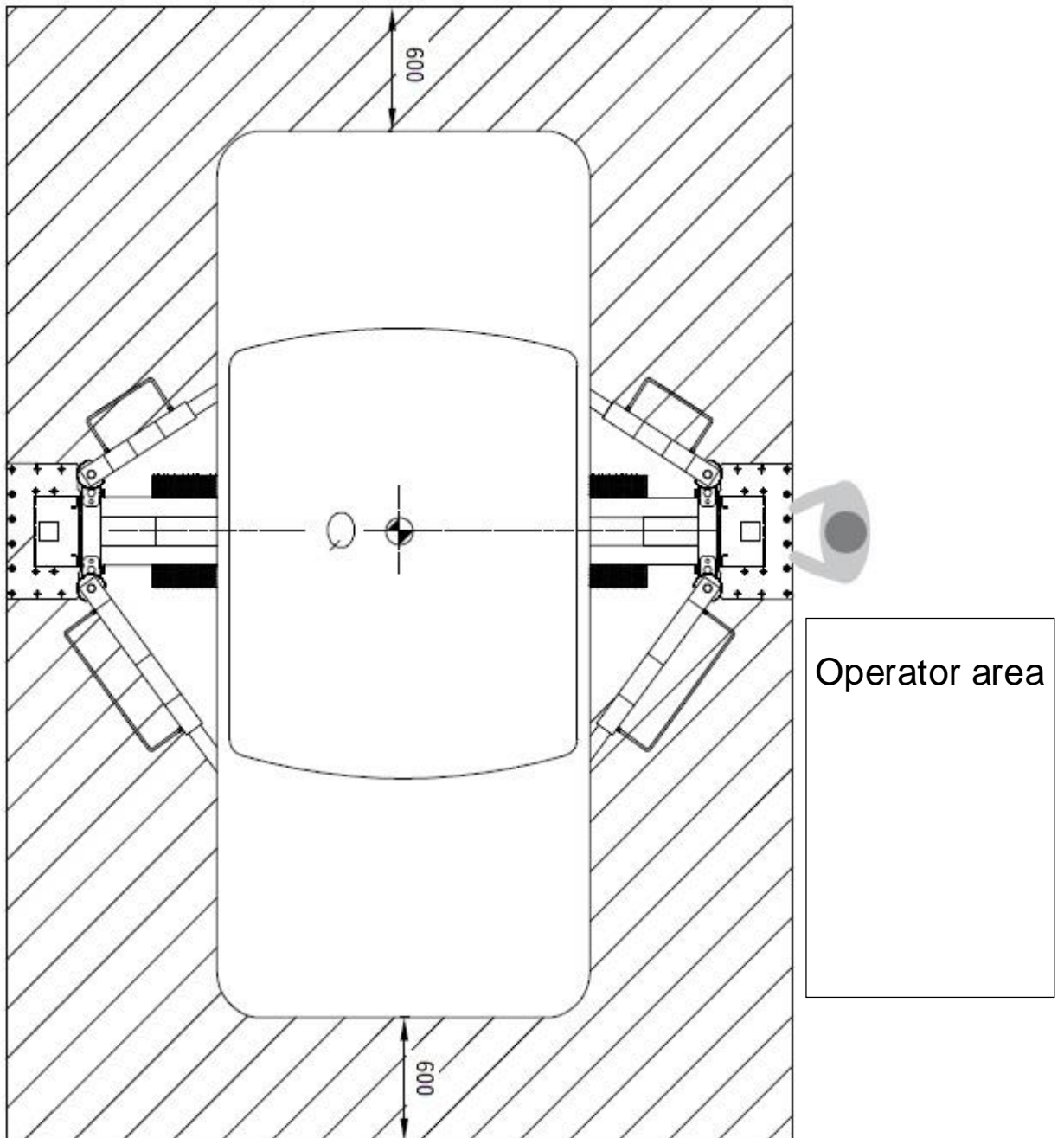

Fig. 5



1.5 HAZARDOUS AREAS



2 - FOREWORD

This manual includes the instructions relating to the installation, use and maintenance of the lift system called "Vehicle Lift". The vehicle lifts described in this manual are designed and constructed solely to lift vehicles for repair, maintenance and inspection purposes. Lift operation, economy and duration depend on the compliance with the instructions given in this manual. The parts that can be supplied also as spare parts are listed in the last section of the manual. To make instructions reading easier, vehicle lift will be hereinafter simply called "lift".

2.1 CE CERTIFICATION

2010/42/EC Directive, commonly known as the "Machines Directive" specifies the conditions to be respected before a machine can be put into the market. This Directive provides that all machines can be marketed and commissioned only if they do not jeopardize people, pets or property safety and health. To certify lift compliance with Directive provisions, before marketing, the manufacturer subjected a machine specimen to the audit of a notified body.

Lift, manufactured in compliance with 2010/42/EC Directive provisions, and can thus be marketed without jeopardizing user's safety.

Lift is thus delivered to the customer with:

- EC Declaration of Conformity
- Instructions for use
- Inspection records

2.2 TESTING

The lift has undergone static and dynamic tests based on the procedures included in the EN 1493:2010. Concerning lift testing, please refer to the relevant section in the Inspection records.



The instructions given in this manual shall be compulsorily respected: the Manufacturer will not be held responsible under any circumstances arising from negligence, from non-compliance with the instructions and from an improper or inconsiderate use of the lift. Failure to comply with the instructions given in the manual makes the warranty directly become null and void.

The Company also disclaims any liability for damages caused by lift improper use and/or due to changes made without the manufacturer's authorization.

3 - GENERAL SAFETY AND ACCIDENT-PREVENTION RULES

FOR A SAFE USE OF THE VEHICLE LIFT DESCRIBED IN THIS MANUAL

THE FOLLOWING IS ALLOWED:

Using lift only to lift vehicles for inspection, maintenance and/or repair operations.

Using lift only to lift vehicles respecting capacity limits and loads distribution indicated in this manual.

Only authorized personnel, in good health conditions, responsible and duly trained on the allowed uses and risks originated by lift use may operate the lift.

The operator is allowed to use the vehicle lift only after he has thoroughly read, understood and assimilated the contents of this manual.

Using lift only inside closed premises, protected against atmospheric agents such as: rain, snow, wind, etc.

Only one operator at a time may use the lift in the safety position in the indicated area, close to the control panel

IS REQUIRED:

- Lift installation and maintenance operations shall be compulsorily carried out by qualified personnel only, and in full compliance with the instructions given in this manual.
- Before installing lift, you shall compulsorily check that the premises where you wish to position it are well aerated and lit. (avoid blinding light sources).
- You shall compulsorily check that the floor where you wish to install lift is solid, flat, and perfectly levelled in all directions.
- You shall compulsorily check that the floor has been constructed to withstand the max. allowed loads, including the lift, on lift resting areas.
- Lift shall be compulsorily positioned far from heat sources or devices that could generate electromagnetic radiation.
- Lift shall be compulsorily positioned so that, during standard operation, with the vehicle loaded on it, it does not interfere with or squash any nearby fixed or moving part. Take special care to power, water and gas systems.
- The lifting or handling operations of lift or of any lift parts shall be compulsorily carried out under full safety conditions with suitable lifting equipment, as envisaged by the National prevailing regulations.
- Lift shall be compulsorily secured to the floor only using anchors and screws of the type recommended by the manufacturer (for lifts, where envisaged).
- Before using the lift, the wholeness of lifting elements shall be compulsorily checked.
- Before using the lift, you shall compulsorily check that safety devices are perfectly installed and in good operating conditions.
- Vehicle shall be compulsorily positioned as shown in the table of the manual and/or the table stuck to lift.
- Vehicle shall be compulsorily lifted from the resting points specified by the vehicle manufacturer.
- When moving vehicle up, after the first 200 mm and before continuing the raising, load stability shall be compulsorily checked in all directions.
- During the whole raising movement, load stability and lift correct and linear movement shall be compulsorily checked.
- Before accessing the working area, lift shall be compulsorily put in mechanical safety position with the special command (where applicable).
- Before accessing the working area, lift shall be compulsorily disconnected from power sources by turning to 0 (zero) the lockable rotating disconnecter positioned onto control panel.
- You shall compulsorily check that the disassembling of some of the parts of the vehicle positioned onto lift does not originate any load unbalance.
- Before starting lift lowering, you shall compulsorily check that no people, animals or things that could interfere with the moving parts are under and around the working area.
- During lowering, you shall compulsorily and constantly check lift and lift load movement. In case of failure, immediately turn emergency disconnecter.
- In case of irregular noise or operating failures, you shall compulsorily stop lift operation, and check the cause of such irregularity. In case of doubt, contact the manufacturer's service department.
- Power supply shall be compulsorily sectioned whenever adjustment, repair or maintenance operations have to be carried out on the equipment.
- All danger signaling decals present onto the lift shall be compulsorily cleaned or changed.
- Lift shall be compulsorily cleaned and all oil spots on the floor cleaned out, as they are very dangerous.
- All ordinary and extraordinary maintenance operations shall be compulsorily and thoroughly carried out, as indicated in this manual; also periodical checks to be recorded on the special "inspection records" coming with the lift shall be compulsorily carried out.
- You shall always compulsorily use the manufacturer's original spare parts.

IT IS FORBIDDEN:

- It is forbidden to misuse lift as well as to use in any other manner not specified in the "INTENDED USE" section of this manual.
- It is forbidden to lift loads with just some of lift parts (one runway only, or two arms only).
- It is forbidden to install lift in hazardous premises containing inflammable and/or explosive substances, or where inflammable gases or vapors can be created.
- It is forbidden to install lift inside premises exposed to atmospheric agents.
- It is forbidden to install lift in premises where washing or sandblasting operations are carried out, or in very dusty premises.
- It is forbidden to install lift on vehicles or watercrafts.
- It is forbidden to use lift in presence of strong magnetic fields.
- It is forbidden to use lift to lift objects other than the specified ones (cases, containers or pallets) or to use it as a hoist.
- It is forbidden to use lift to lift people or animals.
- It is forbidden to lift vehicles with people or animals onboard.
- It is forbidden to use the lift if the room temperature is below 5°C or above 40°C.
- It is forbidden to voluntarily cause load oscillations during raising or lowering maneuvers, or while load is lifted.
- It is forbidden to access work area under the lift without having enabled safety mechanical devices, and turned disconnecter to 0.
- It is forbidden to leave the lift unattended without having positioned it at the min. height or in mechanical safety position. Then section power supply, and lock disconnecter using a padlock.
- It is forbidden to remove or change lift protections or safety devices.
- It is forbidden to change lift or lift parts, any tampering with or change will immediately invalidate warranty, and will relieve manufacturer of any direct or indirect liability for damages due to such tampering or changing operations.
- It is forbidden to use parts or accessories not supplied by the manufacturer.

3.1 SET-UP AND CLOTHING

Set up a space suitable for the machine, and the working environment, by carefully evaluating the following aspects:

- The position shall be safe, free from any hinder, and protected against atmospheric agents. From the control position, the operator shall be able to see the whole system and the working area, and to immediately detect the presence of unauthorized persons and objects that could originate any danger.
- The min. distance of the hazardous area from the walls of the premises where the vehicle lift is installed shall be at least 70 cm. Lighting shall be good, but without blinding or intense lights, and there shall be no sources or processes that could develop gases or flammable vapors.
- Avoid wearing unsuitable clothing. They could get entangled in lift moving parts. As disposed by the National prevailing rule, besides wearing clothes suitable to the work site, the operator will have to compulsorily wear complementary protective accessories to prevent any injury, such as: helmet, goggles, gloves, suitable shoes, etc.

3.2 ENVIRONMENT AND POLLUTION

- Lift shall not be used for vehicle washing, degreasing, sandblasting and grinding.
- Comply with the National prevailing standards relating to the use and disposal of the products used for lift cleaning and maintenance, respecting the manufacturer's recommendations.
- Traps and drainage ditches shall discharge fluids, where and as indicated by the National prevailing standards.

3.3 LIFT SCRAPPING

As for products disposal upon lift scrapping, DO NOT disperse parts in the environment, but contact a company specialized in waste storage. To avoid any environmental pollution risks, take the following precautions:

- The oil contained inside hydraulic control unit, relative circuit and cylinders shall be fully collected. (if available).
- Disassemble lift parts by dividing them into groups of the same material in order to proceed to their separate disposal.
- Exhausted hydraulic oil, rubber parts, and iron scraps are special waste. Dispose of or temporarily store them in compliance with the National prevailing anti-pollution standards.

3.4 DANGER LEVELS

The removal or tampering with the safety devices involves a violation of the European Safety Standards.

- The use of the machine is allowed only in places without risk of explosion or fire;
- The use of original accessories is recommended. Our machines are designed to accept only the original accessories;
- Installation must be carried out by qualified personnel in full compliance with the instructions below;

Check that during the maneuvers there are no dangerous conditions: stop the machine immediately if any functional irregularities are found, and contact the authorized dealer's assistance service



Pay special attention to the following danger sign when you find it in this manual, and follow the safety recommendations. Danger signals have three levels:



DANGER: this signal warns that, if the described operations are not carried out correctly, they cause severe injury, death or health long-term risks.



WARNING: this signal warns that, if the described operations are not carried out correctly, they may cause severe injury, death or health long-term risks.



CAUTION: this signal warns that, if the described operations are not carried out correctly, they may cause machine damage and/or personal injuries.



WARNING: carefully read the following rules; whoever does not put into practice the recommendations described hereinafter may be subject to irreparable damages or cause them to people, animals or property. The Company disclaims any and whatever liability arising from the failure to comply with the safety and accident-prevention rules described hereinafter. The Company also disclaims any liability for damages caused by lift improper use and/or due to changes made without the manufacturer's authorization.



WARNING
The equipment is intended to be used by only one operator at a time.



WARNING Electrical system interventions, even minor ones, require the intervention of professionally qualified personnel (see specific legislation on the subject).

3.5 HAZARDOUS AREAS

Before using the lift, make sure that no unauthorized persons nor animals are present within the hazardous area delimited by the yellow stripe.

Persons or animals shall by no means stop or pass within the hazardous area delimited by the yellow stripe, when using lift even for small movements, and whenever the Emergency Switch/OFF is not depressed.

Each lift is supplied with the identification plates relating to the different versions.

3.6 Safety instructions for lift machines

The safety information described in this manual applies to the lift (FIG. 6) and note warns of unsafe and hazardous conditions. Warning labels and safety warnings should be kept clean and replaced immediately if they fall off or are damaged

Read the meaning of the safety instruction message carefully and remember it

Read the safety instruction message carefully and remember it

3.7 INTENDED USE

The vehicle lifts described in this manual are designed and manufactured for lifting vehicles for inspection, maintenance and/or repair purposes only.

The vehicle lift should be used only for lifting vehicles within the load capacity limits given in the IDENTIFICATION PLATE and in the paragraph 1.3 "LOAD DISTRIBUTION"



CAREFULLY READ THE INSTRUCTIONS GIVEN IN THIS MANUAL BEFORE USING THE LIFT

4 – TRANSPORT AND INSTALLATION

Since the lift is packed in a special wooden crate, it can only be handled using a pallet truck or fork-lift truck, fitting the forks into the slots as shown in figure 2.

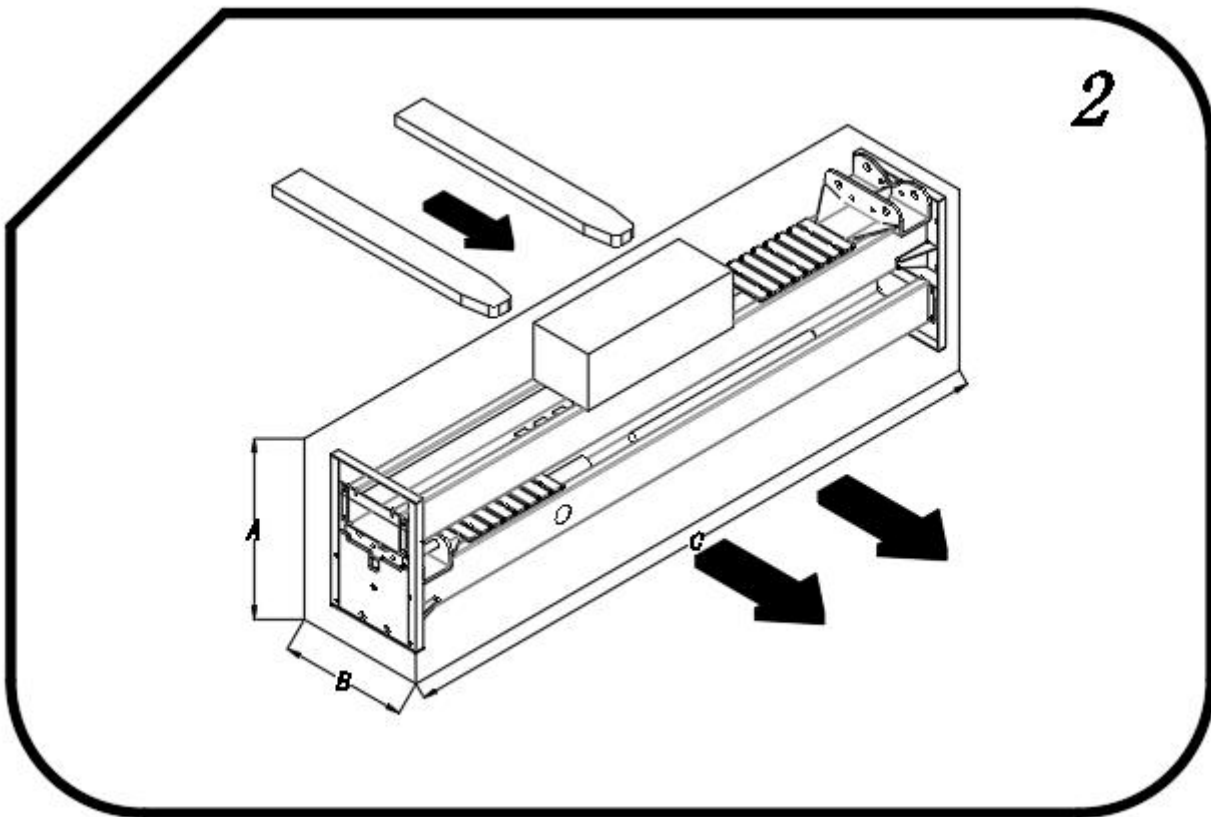

	Packing size	Packing size of pump station
A	700mm	290mm
B	460mm	260mm
C	2900 mm	770mm

4.1 UNPACKING

After removing the packing materials, carefully inspect the various components of the equipment, checking for any visibly damaged parts (control unit, lift frame). Don't leave the packing materials to the place children can get access to. In case of damage do not use the equipment (the lift) and call in a qualified technician (your local dealer).

The packing materials (plastic bags, expanded polystyrene, nails, screws, wood blocks etc.) must never be left within the reach of children as they constitute a potential hazard. Dispose of these materials in the designated collection centers if they are polluting or non-biodegradable.

4.2 INSTALLATION AREA

An area of at least 4330 x 4000 mm, with a ceiling height of at least 3300mm, is required for installation of the lift. From the operator position, the operator is able to monitor the entire lift and its surrounding area. He must ensure that there are no unauthorized persons, or objects which may cause hazards, in this area. Before installing the lift, check the specifications of the supporting surface available, or prepare a surface with the minimum characteristics stated below

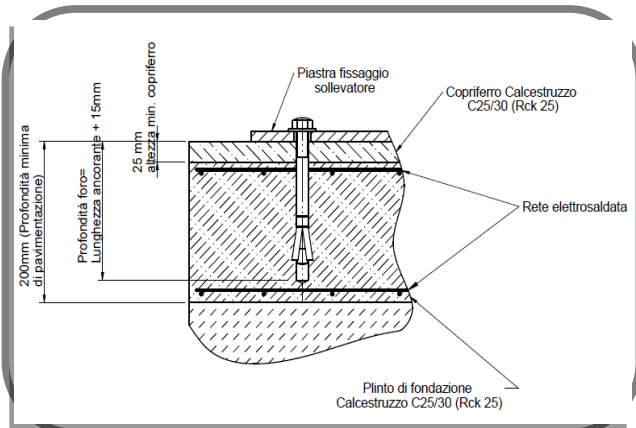

Concrete class 250 R'bk.
Reinforcement Fe B 44 K.

The lift must be fixed to this surface using heavy-duty anchor fixtures as described in the “Anchor Bolt Installation Procedure” section of the manual. The said surface must be capable of supporting at least 25 Kg/cm² and have a strength rating of at least 250 R'bk. The layer of concrete must be sufficient to ensure effective installation of the anchor bolts, and have a good structure to a depth of at least 200 mm.

If a surface of this kind is not available, two separate foundation plinths can be constructed. The minimum characteristics required are:

Dimensions 1000x1000 (figure 3)
Depth 600 mm.
Concrete class 250 R'bk.
Reinforcement Fe B 44 K.

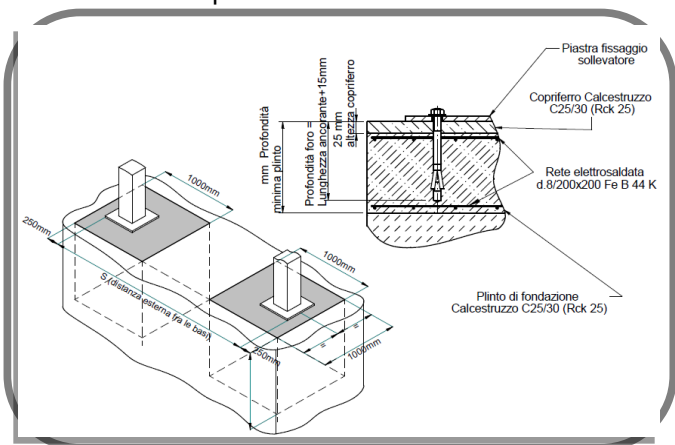

The floor must be able to withstand a load equal to the sum of the weight of the lift itself and the maximum payload, bearing in mind the lift support surface area and anchor fixtures used.



The installation procedure foresees the use of the accessory plugs kit (optional), for equivalent models refer to the table below and / or to the technical sheets of the product used.

model	specifications	Minimum installation depth	Torque (nm)	Pull out the output (KN)
GB22795-M18×160-JD	18	160 mm	100	17.2

4.3 INSTALLATION

After unpacking, handle the pillars with the aid of suitable slings.

Anchor bolt installation procedure:

- 1、 Place the two pillars in the installation zone.
- 2、 Straighten the pillars to the vertical position and then position them so that they are properly aligned with the distance between them (fig. 3).
- 3、 If necessary place shims underneath the bases of the pillars so that they are firmly supported and the pillars are perfectly vertical.
- 4、 Use a drill bit $\varnothing 18$ to drill holes at least 160 mm deep, and clean the holes thoroughly. Install the GB22795-M18x160-JD or equivalent anchor bolt into the hole and tighten it using a torque wrench set to 100 Nm: first place the thick washer in the fastener between the anchor bolt washer and the column bottom plate. After several cycles of running at full load, check that the anchor bolts are still firmly tightened. This test must be repeated every 3 months

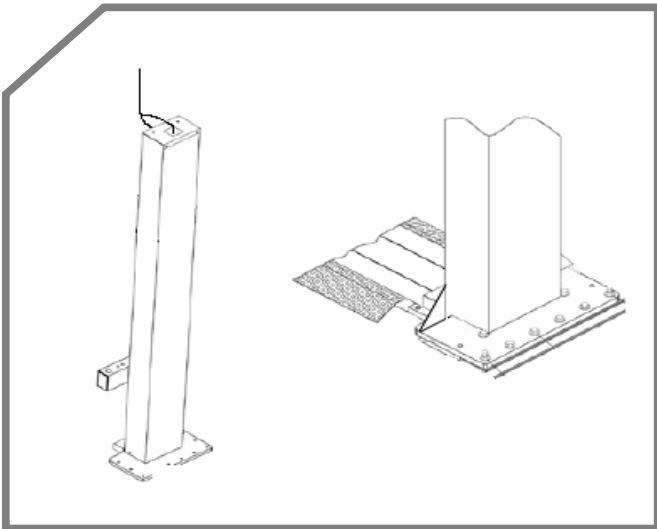
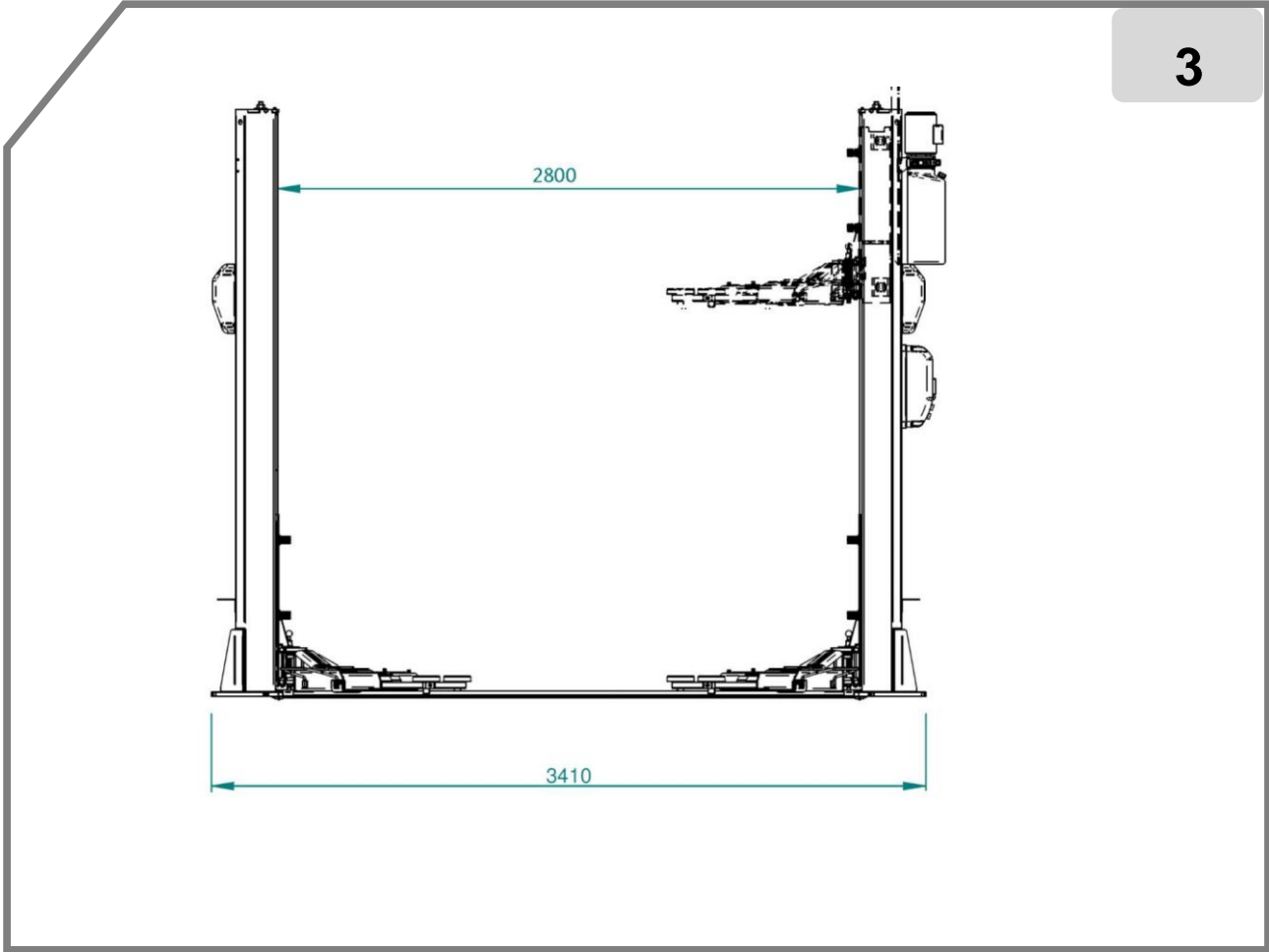



WARNING

The manufacturer declines liability for any damages resulting from failure to follow the above instructions, which may invalidate the warranty.

4.4 CONNECTING TO THE ELECTRICITY MAINS

The lift must be connected to the mains electricity supply by the customer.

To connect to the electricity supply, use a 3 core + earth cable with cross section of 2.5 mm² for the 380V version;

To connect to the electricity supply, use a 2 core + earth cable with cross section of 2.5 mm² for the 220V version

The cable must be completed with a main plug of the type in use in the country where the lift is installed.

The lift is fitted for the mains connection cable to arrive from below, but it can also be received from above.

THREE-PHASE CONNECTION

Once the passage of the cable has been carried out, it must be suitably stripped, the ends of the unsheathed wires and provided with insulating bushings and the appropriate yarns R, S, T, and PE.

It should be remembered that the presence of the PE marking machine is expressly provided for by the electrical regulation EN60204 and therefore it is absolutely necessary to provide for its application.

The conductors must be connected as shown in the diagram figure 14:

The phase conductors R, S, T to the terminals of the QF differential switch, while the PE ground conductor is connected to the special ground rod.(figure 15)

The machine operates normally at 400 Volt 50 Hz (Star). The actual supply voltage is indicated on the identification plate.

The electrical system and the connections are different according to the supply voltage / frequency and are set up in the factory



Figura 14



Figura 15

MONO-PHASE CONNECTION:

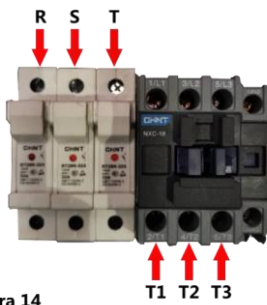
Once the passage of the cable has been carried out, it must be suitably stripped, the ends of the unsheathed wires and provided with insulating bushings and the appropriate yarns L, N, PE.

It should be remembered that the presence of the PE marking machine is expressly provided for by the electrical regulation EN60204 and therefore it is absolutely necessary to provide for its application.

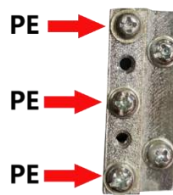
The conductors must be connected as shown in the diagram figure 4a:

The phase conductor L and the neutral N at the terminals of the differential switch QF, while the PE ground conductor is connected to the special ground rod.

Connect the cables coming from the motor on the terminal board in position L1 and N1



Figura 16



Figura 15

WARNING

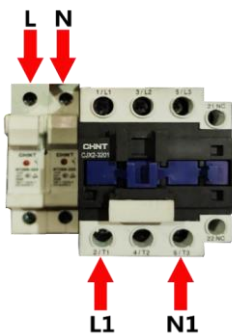
The manufacturer declines liability for any damages resulting from failure to follow the above instructions, which may invalidate the warranty.

Before supplying power to the lift, make the following checks:

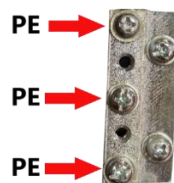
- Check that the power supply voltage and frequency correspond to the values stated on the rating plate.
- Check the condition of the conductors and ensure that the earth conductor is present.
- Ensure that there is an overcurrent protection device installed upstream of the lift, with a differential safety breaker.
- Connect the appliance's cable to the mains socket, wiring the three phases R,S,T and the earth conductor with all due care, and in compliance with the regulations in force.

WARNING

The manufacturer declines liability for any damages resulting from failure to follow the above instructions, which may invalidate the warranty.

WARNING

Any connections to the workshop electrical panel are the customer's responsibility, and must be made by staff qualified in accordance with the relevant legal requirements.

4.5 HYDRAULIC CONNECTION

4.5.1 Installation of pump station

4.5.2 Short tubing connection

4.5.3 Long tubing connection

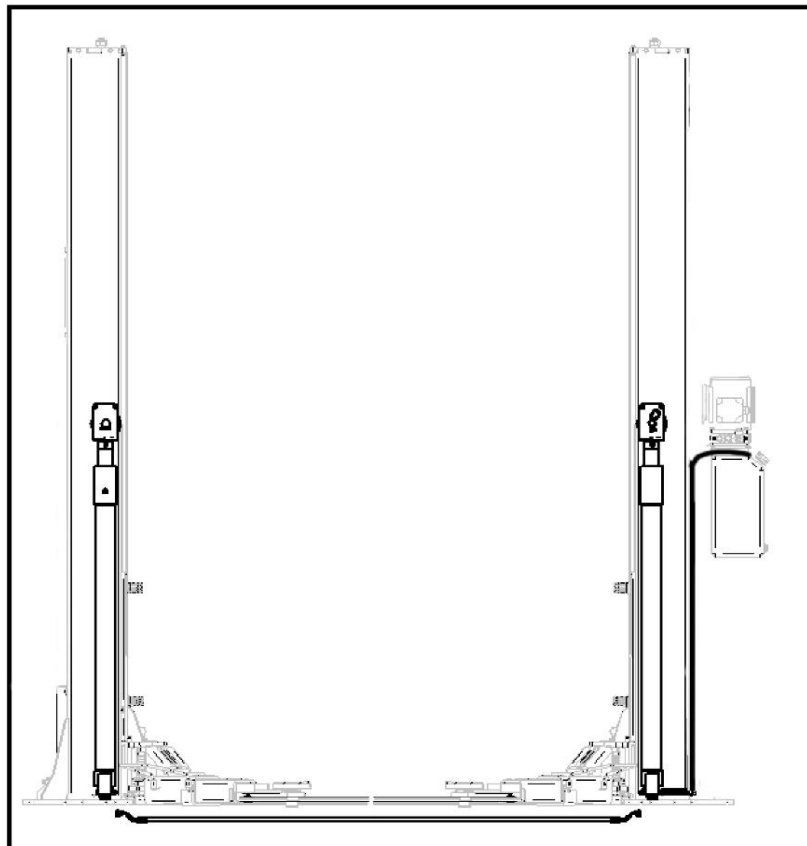



ATTENTION: when connecting oil pipes, please use two wrenches to fix to avoid leakage caused by untightened fixing.



WARNING

Check that there are no oil leaks, if necessary, switch off the voltage and tighten the loose hydraulic connections.

The lift to work requires ISO VG32 viscosity hydraulic oil not supplied. (Optional).
Unscrew the oil filler cap and insert 9 liters of hydraulic oil into the tank.

4.6 CONNECTION CABLES OF SYNC

To connect the synchronism cables between the two columns:

- A)Lift the arm to the position at half height and stop them in safe position. The two carriage must be perfectly aligned and positioned in the same rack of the guide;
- B) Wire rope A is connected to P1 column through the bridge bottom plate between the two columns. At this time, the wire rope wheel at the bottom of P1 column needs to be removed. After wire rope A is installed, it is fixed again with a spring.
- C Repeat the same operation, connect the wire rope B, starting with the slide body built into column P1 and connecting to that located in column P2
- D)Adjust the tension evenly by using the locking nut in carriage and keep the same tightness for cable a and b, until the safety locks in both pillar 1 and pillar 2 keep in sync.

Figure 20

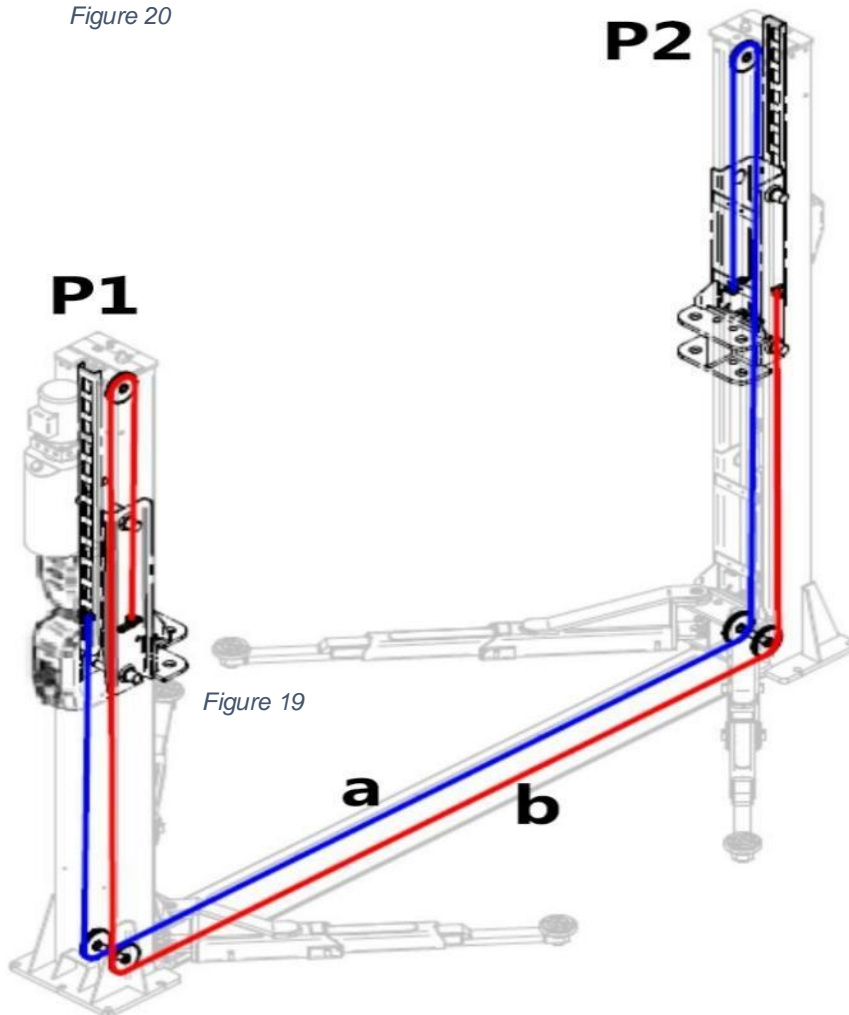

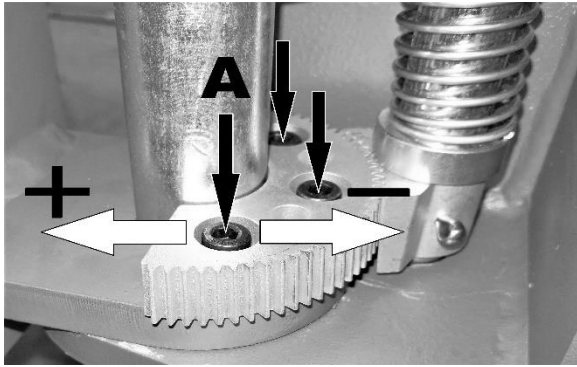

Adjustment of the arms looking

Unscrew the screws A (see picture).

near to the pin (marked-) or move away (marked +) until the gear engages properly.

After adjustment, tighten the screws A.

4.7 CHECK THE MOTOR ROTATION DIRECTION

Use the up button. If the carriage **does not move up**, please exchange two wires inside the power cord plug.



WARNING

The motor rotation direction must be checked whenever the lift's power source is changed.

4.8 EXHAUSTING OF HYDRAULIC SYSTEM OF LIFT

When the equipment is in use, tear off the label of the air hole on the cylinder

5 – INSTRUCTIONS FOR USE

5.1 START UP



WARNING

The lift must be put into service by specially trained personnel, in order to assure the correct functioning of the lift itself and all its mechanical and electrical safety systems.

The instructions to be followed are provided in the final section of this manual, for the use of the technicians who carry out the start-up procedure only.

No work on the part of the staff that does not belong to the after-sales service of the manufacturer must be permitted.



WARNING

The manufacturer declines liability for any damages resulting from failure to follow the above instructions, which may invalidate the warranty.

5.2 UTILIZATION

The machine must only be used by authorized personnel. Use by personnel who are not familiar with the procedures specified in this manual could be dangerous.

The operation of the machine is as follows:

Vehicle positioning

When positioning the vehicle over the pads, pay attention to the following recommendations:

- a) the total weight of the vehicle must not exceed 4000 kg
- b) place the vehicle on the pads, making sure that it is aligned and centered with respect to the longitudinal axis of the lift.
- c) the maximum load of 4000 kg must be distributed on the four vertices of a rectangle having a transverse dimension of 1000 mm and a longitudinal dimension of 1800 mm. For lower transverse distance values and / or longer longitudinal distance the lift capacity is reduced. In these cases or in other cases not covered by this manual it is advisable to contact the manufacturer.
- d) the use of accessories not authorized by the manufacturer to modify the support distances of the lifting pads is forbidden.

- e) The method of lifting the load must not present dangers and must observe the rule that requires stopping after a short lift to check that the vehicle is correctly positioned and in a safe condition.



The Manufacturer disclaims any and whatever liability for damages to persons, animals or property arising from non-compliance with the instructions given herewith and/or from an improper use of the lift or any use other than specified in this manual.

To lift vehicle, proceed as follows:

- Check that the arms are turned in a way that will not hamper the vehicle access between the lift columns.
- Turn the arms and pull out the extensions bringing the pads to the points designed for lifting the vehicle as indicated by the vehicle manufacturer.

WARNING:

Before lifting a vehicle, always check the load distribution with respect to the vehicle mass, strictly complying with the LOAD DISTRIBUTION table (Fig. 3). Do not lift the vehicle in case the values found are not within the limits given in the LOAD distribution table.

Lifting of the vehicle

- Press the power unit button (1) and lift for about 30 cm, check that the support points have a correct grip; if correct, continue the climb until the desired working height is reached. Carefully check the stability of the load throughout the climb.
- In the event that there is a precarious stability of the vehicle or abnormal operation of the lift itself, immediately stop the maneuver to climb, wait for the stabilization of the load and proceed with small descents to the ground. Reposition the load correctly or proceed to stop the lift if the cause of the instability turns out to be of a technical nature

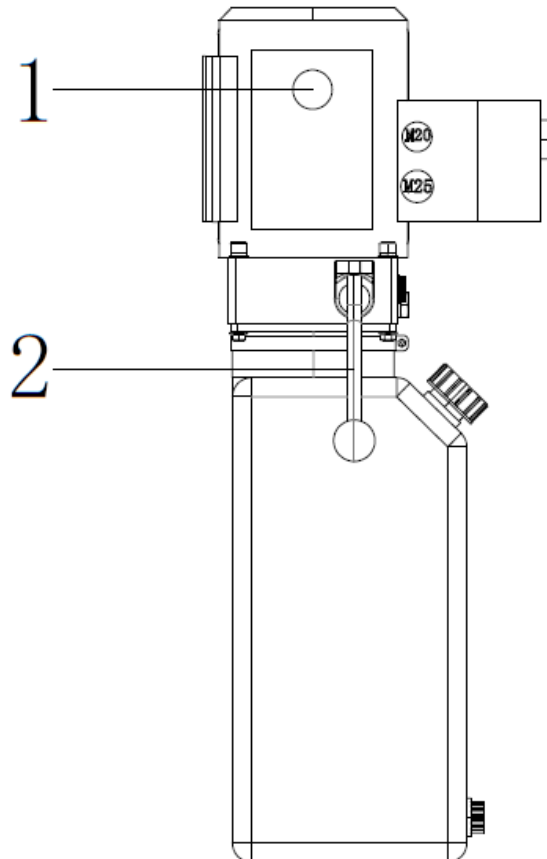

Descent of the vehicle

Press the power unit button to lift 5CM, so that the carriage is unlocked, and pull the unlocking ropes on both sides to release the locks on both sides.

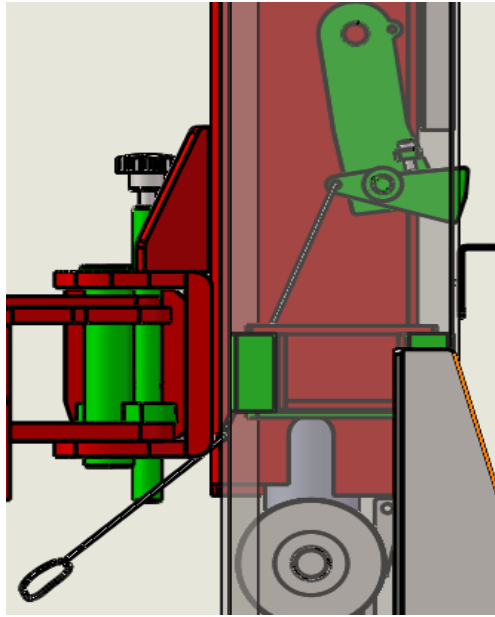

manually push down the pressure lever (2) in power unit, and the descent can be realized.

During the entire descent, carefully check the stability of the load.

In the event that a precarious stability of the vehicle or abnormal operation of the lift is found, immediately stop the maneuver, wait for the stabilization of the load and proceed with small descents to the ground. Reposition the load correctly or proceed to stop the lift if the cause of the instability turns out to be of a technical nature.



WARNING

The vehicle must only be lifted to the lifting points prescribed by the vehicle manufacturer.

For assistance, contact authorized centers and request the use of original parts.

5.3 EMERGENCY PROCEDURES

These modes are intended for handling emergency situations which may arise due to malfunction, incorrect loading, power failure, etc.



This maneuver can only be carried out in the presence of the manual pump (optional)

The purpose is to enable the operator to retract the runways of the lift in order to allow for removal of the vehicle. Emergency procedures may be executed by the user, but we recommend contacting our technical service department to clear up any uncertainties first.

Emergency procedures are potentially hazardous and must be executed with extreme caution: make sure that all persons are at a safe distance from the lift before proceeding.

Manual Emergency Maneuver

In order to lower the lift in the event of a current supply interruption, follow the following steps:

1. Turn off the power
2. Use a manual pump (optional) to lift about 5CM until the mechanical safety lock is released.
3. Pull the unlocking ropes on both sides to release the locks on both sides.
4. Gently lower the arm to the ground position.



WARNING

Never leave a manual emergency operation on hold as the lift could slowly misalign. Stop or cancel the manual emergency operation, if necessary.

6 - MAINTENANCE

To guarantee the efficiency of the machine and its correct functioning it is essential to follow the following instructions:

- Lubricate the chains and sprockets once a month with VANGUARD EP 68 or equivalent
- Check the tightening torque of the anchor bolts and check the tightness of the anchor bolts every three months. The M16 bolt is 100 Nm
- lubricate the cable with lithium grease and check if it is crushed or cut
- Check whether the pulley works properly
- Lubricate the slider with lithium grease and check whether the slider works properly
- Check the oil level in the pump station tank
- When cleaning a lift, pay special attention to any foreign matter that may cause mechanical and electrical safety device failure



ATTENTION:

after installing the machine, grease and maintain the cable, sprocket, chain and pad with lithium base grease.

Cleaning

To clean the machine (columns and plastic covers) use only a soft cloth, if necessary soaked in non-aggressive detergent. Do not use solvents (petrol, turpentine, acetone and the like). Cleaning the space between the columns should be done simply by sweeping away the dirt.



WARNING

Never use pressurized water (eg water cleaners) to clean the machine.

STORAGE

If the lift is to be out of use for a long period of time, it must be disconnected from the electricity supply and any parts which might be damaged by dust must be protected.

ENVIRONMENTAL INFORMATION

The disposal procedure described below must only applies to machines with the symbol of the waste bin with a bar across it on their rating plates 

This product may contain substances which may cause damage to the environment and human health if not disposed of properly.

We are therefore providing you with the information below in order to prevent these substances from being released into the environment, and to improve the use of natural resources.

Electrical and electronic equipment must not be disposed of with ordinary municipal waste; it must be disposed of separately by authorized facilities.

The symbol of the waste bin with a bar across it, which appears on the product and on this page, reminds users that the product must be disposed of properly at the end of its working life.

This prevents the inappropriate disposal of the substances which this product contains, or the improper use of some of them, from having hazardous consequences for the environment and human health. It also helps to ensure the recovery, recycling and reuse of many of the materials these products contain.

To allow this, the producers and distributors of electrical and electronic equipment organize special systems for the collection and disposal of such equipment.

At the end of the product's working life, contact your dealer for information about disposal procedures.

When you purchase this product, your dealer will also inform you that you may return another worn-out appliance to him free of charge, provided it is of the same type and has provided the same functions as the product just purchased.

Anyone disposing of the product otherwise than as described above will be liable to prosecution under the legislation of the country where the product is scrapped.

We also urge you to adopt other environment-friendly practices: recycle the internal and external packaging which comes with the product and dispose of spent batteries (if the product has them) properly.

With your help, we can reduce the amount of natural resources used to produce electrical and electronic equipment, minimize the use of landfills to dispose of old products, and improve quality of life by preventing the discharge of potentially hazardous substances into the environment.

FIREFIGHTING EQUIPMENT TO BE USED

For guidance on the most suitable type of ex-tinguisher, refer to the table below:

	Dry materials	Inflammable liquids	Electrical equipment
Water	YES	NO	NO
Foam	YES	YES	NO
Powder	YES	YES	YES
CO ₂	YES	YES	YES

YES* Can be used if more suitable equipment is not available, or for small fires.



WARNING

The information in this table is of a general nature and is intended to provide users with general guidance. Contact the manufacturer for details of the applications of each type of extinguisher.

7 – Problem solution

Problem	cause	solution
No operation	Electrical system failure	exchange the positions of the two power cables
The lift does not complete the lifting stroke	Load exceeding the maximum flow rate	Check the maximum capacity of the lift
	Supply voltage too low	Check the supply voltage
	Low oil level	Fill the oil level
Noise during the ascent or descent movement	Mechanical parts (chain, pulleys, sliding pad) without lubrication	Provide for lubrication
Lift can not completely lower down.	The mechanical locking gear is not open	Check that both mechanical locks are fully open
Poor synchronisation of the carriage	The levelling cables have a different adjustment	Adjust the nut on the ropes
The lifter struggles to up and to down	The down (YV1) valve is open or damaged	Disconnect the down valve and clean it. If it is damaged proceed with the replacement
Oil leakage from connections	Loose fittings.	Tighten fittings, replace if necessary
When the lift button is released, the lift will automatically descend	Explosion-proof valve clearance is too small or closed	Remove the explosion-proof valve and adjust the clearance to about 1mm
Other		If you cannot resolve the problem contact our service.

8 – SCHEMES

8.1 HYDRAULIC CONNECTION DIAGRAM

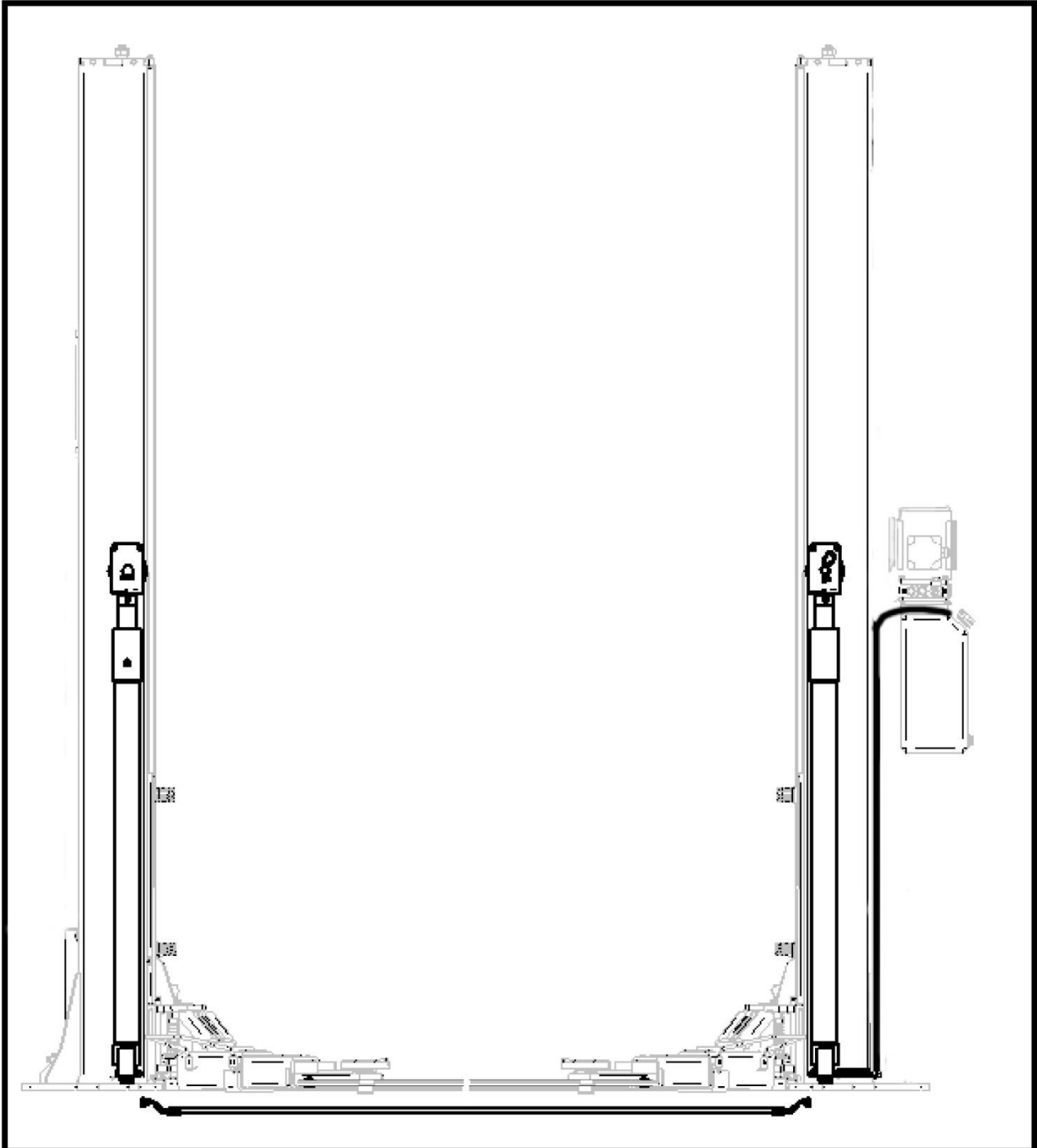

8.2 HYDRAULIC DIAGRAM

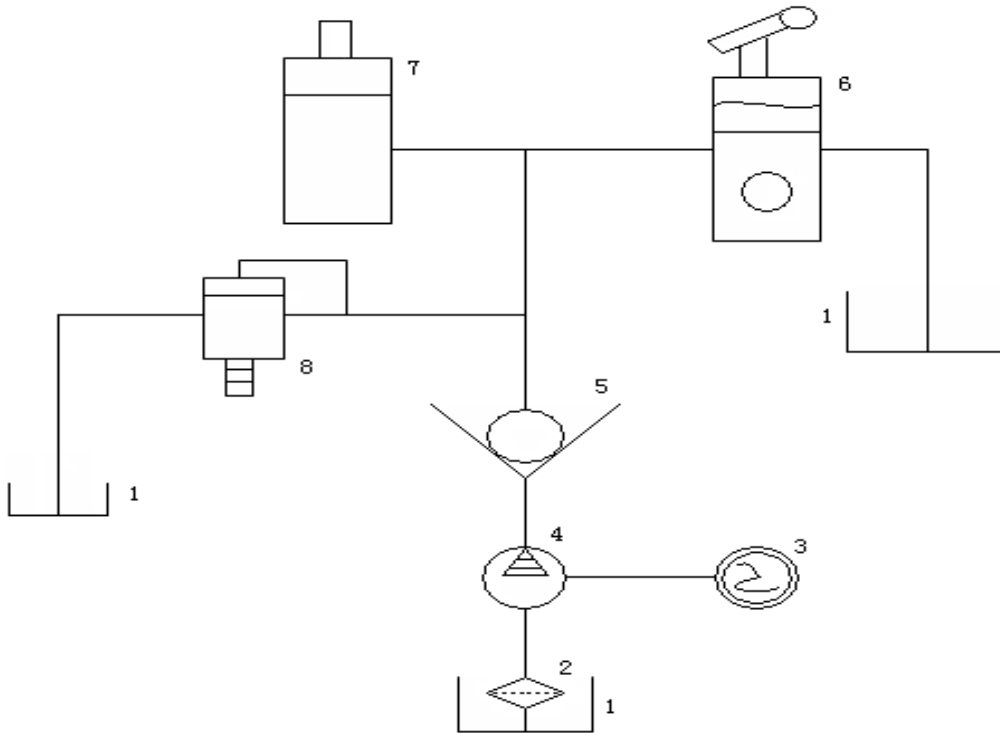

1、 OIL TANK	2.net type oil filter TLW-12
3. Motor Y90L-4.	4. Oil pump CBN-E3
5.Single direction valve	6. manual control valve
7.Oil cylinder	8. Relief valve

PROCEDURE FOR THE ADJUSTMENT AND TESTING OF THE LIFT

RESERVED FOR THE INSTALLER TECHNICIAN
(to be carried out scrupulously by the installer at every point)

• ADJUSTMENT OF MECHANICAL ALIGNMENT OF TROLLEYS

1. press the up button and check the correct direction of rotation of the motor (the carriages must rise) otherwise change two phases on the terminal board.
2. lift the carriages to about 50 cm and measure the height. If there is a difference, tension the synchronism cables.

• TESTING OF THE LOADING BRIDGE FUNCTIONS

- CHECKING OF THE DEVICE AND SAFETY LIMIT SWITCH TENSIONING CHAIN (FC1 / FC2)
- CHECK THE CORRECT OPERATION OF EM1 / EM2 ELECTROMAGNETS, POSSIBLE TO ADJUST NEW
- VERIFY CORRECT LUBRICATION OF MOVING ORGANS
- VERIFY THAT THE VALVE OF MAXIMUM IN CENTRAL UNIT DOWNLOADS TO HIGH MECHANICAL FINECORSA
- CHECK THAT THE ARM LOCKING SAFETY RACKS LAYS IN THE VARIOUS POSITIONS (ARM OPEN ALL OPEN AND ARM ALL CLOSED)

Note